

403-12 HAY PRO TRUCK & TRAILER MIXER

**MODEL NUMBER
403-12 TRUCK
403-12 TRAILER**

ASSEMBLY, OPERATION AND PARTS MANUAL

ROTO-MIX
P.O. box 1724
2205 E. Wyatt Earp Blvd.
Dodge City, Kansas 67801
(620) 225-1142

© ROTO-MIX 2006

INTRODUCTION

Congratulations on the purchase of your new mixer from Roto-Mix. With proper operation and preventative maintenance it will last for years.



This **SAFETY ALERT SYMBOL** indicates important safety messages in the manual. When you see this symbol, be alert to the possibility of **PERSONAL INJURY** and carefully read the message that follows.

⚠ WARNING NEVER OPERATE WITHOUT ALL COVERS, SHIELDS AND GUARDS IN PLACE. KEEP HANDS, FEET AND CLOTHING AWAY FROM MOVING PARTS.

Some covers and guards have been removed for illustrative/photographic purposes only in this manual. However, equipment should never be operated in this condition. Keep all shields in place. If shield removal becomes necessary for repairs, replace the shield prior to use.

The Guarantee appears in the front of this book along with the Registration and Inspection Certificate.

For information on ordering repair parts, refer to the Repair Parts section at the back of this book.

The serial number and model number tag is located on a metal plate which is attached on the inside of the lower left front structure viewed from behind the mixer. These numbers should be recorded on the Registration and Inspection Certificate for your reference and for proper identification of your mixer by Roto-Mix.

You are urged to study this manual and follow the instructions carefully. Your efforts will be repaid in better operation and service as well as a savings in time and repair expense. Failure to read and understand the machine or the system could lead to serious injury. If you do not understand the instructions in this manual contact either your dealer or Roto-Mix at Dodge City, Kansas 67801.

This supersedes all previous published instructions.



Limited Warranty Statement

ROTO-MIX LLC warrants to the original purchaser all products manufactured by it to be free from defects in material and workmanship under normal use and service.

ROTO-MIX's obligation under this warranty is limited to repairing or replacing, as the company may elect, free of charge and without charge for installation, at the place of business of a dealer or distributor authorized to handle the equipment covered by this warranty or at a ROTO-MIX facility, any parts that prove, in the company's judgment, to be defective in material or workmanship within one (1) year after delivery to the original purchaser, and still owned by the original purchaser. This warranty shall in no way make ROTO-MIX liable to anyone for personal injuries or damages, loss of time, or expense of any kind either direct or indirect resulting from part failure or defect. This warranty is subject to acts of God, fire and existing conditions of supply and demand, or production, or ability or inability to deliver, or for any other valid reason beyond the reasonable control of ROTO-MIX, to obtain materials, manufactured replacement parts, or make delivery thereof. No distributor, dealer, agent, or ROTO-MIX employee (other than the CEO or President in writing) is authorized to extend any other or further express or implied warranty or incur any additional obligation on ROTO-MIX's behalf in connection with the sale of this product.

If ROTO-MIX, or its duly authorized representative, shall find that such returned part or parts are defective and such defects, or defect, are included in and covered by said warranty, then such defective part or parts shall promptly be replaced without charge to the purchaser, F.O.B. the ROTO-MIX plant.

Product Registration - It is a condition of this warranty that the original purchaser must fill out the warranty card furnished by ROTO-MIX and that it be returned to ROTO-MIX within 10 days of purchase and be recorded in ROTO-MIX's owner file for this warranty to be valid. In the event an owner's card is not on file at the ROTO-MIX office, the warranty period will extend only from date equipment was picked up or shipped from the ROTO-MIX plant.

Maintenance - It is the customer's responsibility to maintain their equipment in accordance with the instructions provided in the Operator's Manual. ROTO-MIX recommends that you keep records and receipts; you may be asked to prove that maintenance instructions have been followed.

Operation - It is the customer's responsibility to operate the equipment only for the purpose for which it was designed and in accordance with all safety and operational recommendations contained in the Operators Manual. If a defect in materials or workmanship occurs, it is the customer's responsibility to cease operating the equipment until authorized repairs are made. **Damage, which occurs from continued operation, may not be covered by this warranty.**

What this Warranty Covers

This warranty covers failures caused by defects in materials or workmanship only.

This Warranty does not cover failures caused by:

- Improper operation
- Natural calamities
- Unauthorized modifications
- Unauthorized repairs
- Use of Non ROTO-MIX parts
- Neglected maintenance
- The use of PTO Shaft Adaptors
- Usage contrary to the intended purpose of the product

Warranty continues on the next page.

Limited Warranty Statement continued

This Warranty does not cover replacement of Wear or Maintenance Items including, but not limited to.

- | | | | |
|--------------|----------|-------------|----------|
| - Lubricants | - Tires | - Chains | - Blades |
| - Filters | - Augers | - Idlers | - Belts |
| - Hoses | - Wipers | - Batteries | |

This Warranty does not cover:

- Pickup and delivery of the equipment
- Service Calls or Travel Time to and from sites
- Rental of replacement equipment during repair period
- Products that have been declared a total loss and subsequently salvaged
- Overtime labor charges
- ROTO-MIX is not responsible and will not be liable for damage caused to persons or property, commercial loss, loss of time or production, loss of use by reason of the installation or use of ROTO-MIX products or their mechanical failure.

Right to Make Changes

ROTO-MIX reserves the right to make any changes to a ROTO-MIX product at any time without incurring any obligation with respect to any product previously ordered, sold or shipped, with or without notice.

Parts Warranty

ROTO-MIX warrants replacement parts against defects in materials or workmanship for a period of 90 days or the remainder of the product warranty, whichever is longer. Remedy for defective replacement parts for units that are beyond the original product warranty, will be limited to replacement of the failed part. Failures that are due to damage, improper installation, lack of maintenance or improper operation will not be covered.

ROTO-MIX 2205 East Wyatt Earp Blvd., Dodge City, KS 67801 (620) 225-1142 Fax: (620) 225-6370

SCALES WARRANTY & SERVICE POLICY

DIGI-STAR SCALE SYSTEMS

Digi-Star, LLC warrants for a period of one year from date of installation, to correct by repair or replacement, at Digi-Star's option, any defect in material or workmanship in any part of this product. In the event of replacement, Digi-Star's sole obligation shall be to provide replacement products or parts. F.O.B. Digi-Star, LLC, W5527 Hwy 106, Fort Atkinson, WI 53538 USA.

WEIGH-TRONIX SCALE SYSTEMS

WEIGH-TRONIX warrants for a period of one year from date of installation, to correct by repair or replacement, at Weigh-Tronix's option, any defect in material or workmanship in any part of this product. In the event of replacement, Weigh-Tronix's sole obligation shall be to provide replacement products or parts. F.O.B. Avery Weigh-Tronix, 1000 Armstrong Drive, Fairmont, MN 56031-1439 USA.

TABLE OF CONTENTS

Introduction	2
Warranty	3
Scales Warranty & Service Policy	4
Safety- Trailer Mixer.	6
Safety Decals	7
Mixer Safety	8
Safety Decal Care.	11
Specifications	12
Dimensional Data - Trailer Models	12
Dimensional Data - Truck Models	13
Features.	14
Pre operation	15
Tractor drawbar	15
Adjust Trailer Hitch Clevis.	15
Pre Operation Checklist.	15
Tractor Hydraulic System Recommendations.	16
Trailer Operation	17
PTO Engagement.	17
Cornering	17
Loading Instructions & Precautions	17
Discharging Feed	17
Scale Swing Mount	17
Scale System	17
Highway And Transport Operation	17
Lighting And Marking	18
Truck Operation	19
Truck	19
Scale System	19
Following Operation:	19
Loading Instructions & Precautions	19
Discharge Feed	19
Scale Swing Mount	19
Scale System	19
Highway And Transport Operation	19
Lighting And Marking	20
Maintenance	21
Read The Following Before Welding On This Mixer/Feeder	21
Lubrication - Trailer Mounts	22
Lubrication - Truck Mount	23
Troubleshooting	24
Optional Component Installation	25
Scale Mounting (Truck Mount Only)	25
Installing Battery On Mixer (Trailer Mount Only)	25
Repair parts	27

SAFETY- TRAILER MIXER

A brief definition of signal words that may be used in this manual:

⚠ DANGER Indicates an imminently hazardous situation that, if not avoided, will result in death or serious injury.

⚠ WARNING Indicates a potentially hazardous situation that, if not avoided could result in death or se-

rious injury, and includes hazards that are exposed when guards are removed.

⚠ CAUTION Indicates a potentially hazardous situation that, if not avoided may result in minor or moderate injury.

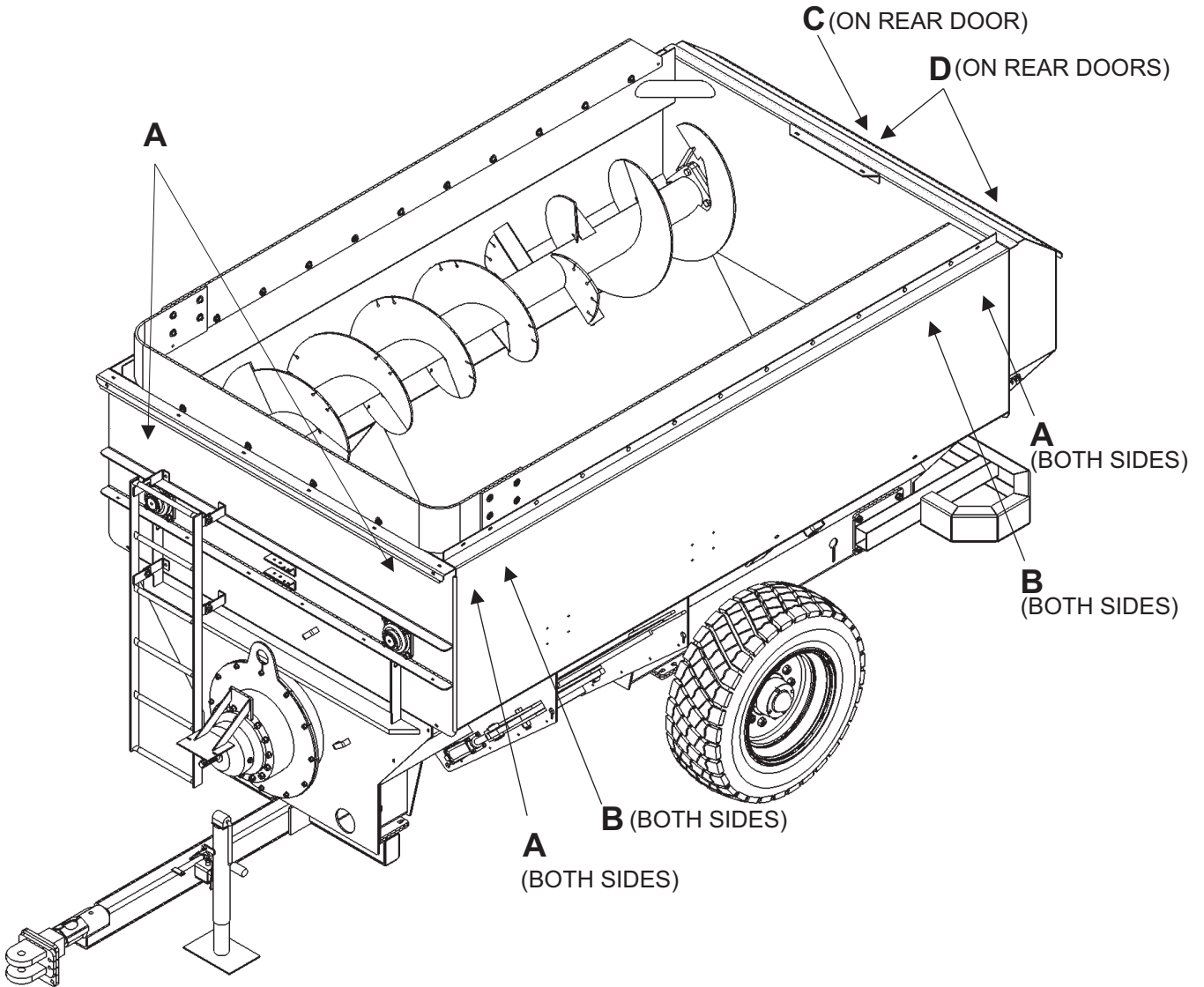

⚠ CAUTION READ ALL SIGNS ON THE MACHINE AND IN THIS MANUAL. REPLACE ANY LOST OR DAMAGED SIGN BY ORDERING THE PART NUMBERS SHOWN ON THE SAFETY DECAL PAGE.

SAFETY DECALS



DECAL A. 440827

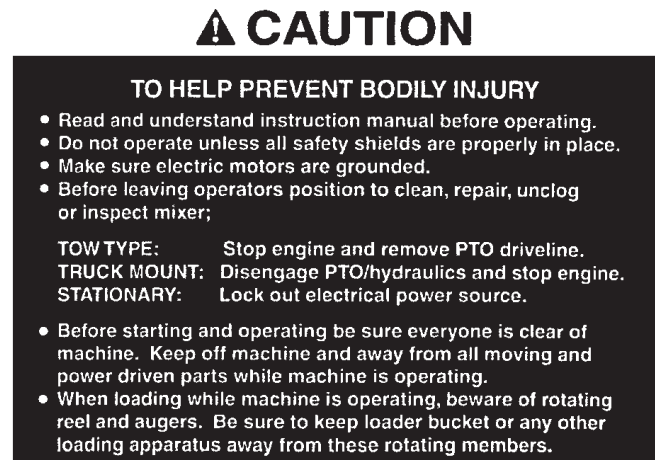

DECAL C. 440819



DECAL B. 440831



DECAL D. 440822

NOTE: See Page For Complete Decal Kit (all sizes and models)

MIXER SAFETY

⚠ CAUTION

Do not operate your feed mixer until you have read this Owner's Manual, the Truck Owner's Manual, and understand the danger associated with its operation.

This feed mixer is comprised of rotating drive shafts and mixing augers. Any exposure to these mixer components can result in serious personal injury or death.

Study the safety decal page associated with your model mixer and understand where the danger points are.

On truck or trailer mounted mixers, never allow operating personnel to be above the level of the feed mixing chamber. Entry into the mixing chamber while the mixer is running will result in serious injury or death.

⚠ CAUTION

THERE ARE INHERENT HAZARDS ASSOCIATED WITH THE OPERATION OF YOUR MIXER.

FOR YOUR SAFETY:

- Do Not Operate, Service, Inspect Or Otherwise Handle This Equipment Unless You Have Read The Owner's Manual And Have Been Properly Trained In Its Intended Usage.
- Do Not Attempt To Operate This Equipment Under The Influence Of Drugs Or Alcohol.
- Do Not Allow Personnel Other Than The qualified Operator Near The Machine.
- Require All Personnel Who Will Operate This Machinery Or Perform Service, To Read And Understand The Safe Operating Practices And Safety Precautions In This Manual.
- Before Starting Tractor Engine, Be Sure PTO Shields Turn Freely.
- Do Not Operate Until All Shields, Covers And Guards Are In Place.
- Do Not Allow Children Or Inexperienced Person To Operate This Machine.
- Keep Hands, Feet And Clothing Away From Power Take-off Shaft.
- Loose Or Floppy Clothing Should Not be Worn By The Operator.
- Do Not Climb On Or Enter Machine While In Operation.
- Do Not Make High Speed Maneuvers With A Mounted Mixer.
- Do Not Allow Riders On The Mixer.
- Rotating Parts Can Crush Or Dismember Causing Personal Injury Or Death.
- Rotating Parts Can Entangle Or Strike People, Resulting In Personal Injury Or Death.
- Never Enter A Mixer/Feeder While In Operation.
- Operate The Mixer/Feeder From The Operator's Seat Only.

- Do Not Exceed Load Capacity Of The Mixer/Feeder. (See Loading Instructions).
- Reduce Speed When Turning Or Traveling On Rough Terrain. Avoid Traveling Over Loose Fill, Rocks, Ditches Or Holes.
- Do not operate on steep slopes as overturn may result. Operate up and down (not across) intermediate slopes. Avoid sudden starts and stops. Pick the most level possible route when transporting across fields. Avoid the edges of ditches or gullies and steep hillsides.
- Keep Transmissions In Gear When Traveling Downhill.
- Stay Clear Of Rotating drive lines.
- Entanglement In Rotating drive line Can Cause Serious Injury Or Death.
- Keep Tractor Master Shield And drive line Shields In Place At All Times.
- Make Sure Rotating Shields Turn Freely.
- Wear Close Fitting Clothing. Stop The Engine And Be Sure PTO drive line Is Stopped Before Making Adjustments, Connections, Or Cleaning Out PTO Driven Equipment.
- Keep Sparks, Lighted Matches, And Open Flame Away From The Top Of Battery. Battery Gas Can Explode.
- Avoid overhead wires or other obstacles. Contact with overhead lines could cause serious injury or death.
- As a precaution, always recheck the hardware on mixer/feeder following every 100 hours of operation. Correct all problems. Follow the maintenance safety procedures.

FAILURE TO HEED MAY RESULT IN SERIOUS PERSONAL INJURY OR DEATH.

⚠ CAUTION

THERE ARE ADDITIONAL HAZARDS ASSOCIATED WITH THE SERVICE AND MAINTENANCE OF YOUR MIXER.

FOR YOUR SAFETY:

- Disengage Power Take-off And Remove Keys From Tractor Or Truck Before Servicing A Mounted Mixer.
- Do Not Attempt To Clean, Oil Or Adjust Mixer While It Is In Motion.
- Stop The Engine And Be Sure PTO drive line Is Stopped Before Making Adjustments, Connections, Or Cleaning Out PTO Driven Equipment. Disconnect PTO Shaft.
- Make sure there is plenty of ventilation. Never operate the engine of the towing vehicle in a closed building. The exhaust fumes may cause asphyxiation.
- Before working on the mixer/feeder, stop the towing vehicle, set the brakes, disengage the PTO and all power drives, shut off the engine and remove the ignition keys.
- Be certain all moving parts on attachments have come to a complete stop before attempting to perform maintenance.
- Before Entering Mixing Chamber Or Servicing Mixer, Disconnect Main Power Source And Lock The Disconnect Device In Off Position To Prevent Accidental Start-up.
- Do Not Work Under A Trailer Mixer Without Supporting With Suitable Support Stands. Always use a safety support and block the wheels. Never use a jack to support the machine.
- Do Not Work Under A Mixer Without Blocking The Wheels To Prevent Rolling.
- A fire extinguisher and first aid kit should be kept readily accessible while performing maintenance on this mixer/feeder.
- Never Check Battery Charge By Placing A Metal Object Across The Posts. Use A Volt-Meter Or Hydrometer.
- Do Not Charge A Frozen Battery; It May Explode. Warm Battery To 16c(60f)
- Escaping Hydraulic Fluid Under Pressure Can Penetrate The Skin Causing Serious Injury Or Death.
- Avoid The Hazard By Relieving Hydraulic Pressure Before Disconnecting Hydraulic Or Other Lines. Tighten All Connections Before Applying Pressure.
- Search For Hydraulic Leaks With A Piece Of Cardboard. Protect Hands And Body From High Pressure Fluids. Never use your hands to locate hydraulic leaks on attachments.
- Replace all shields and guards after servicing and before moving.
- Do not allow grease or oil to build up on any step or platform.
- Never replace hex bolts with less than grade five (5) bolts unless otherwise specified.

FAILURE TO HEED MAY RESULT IN SERIOUS PERSONAL INJURY OR DEATH.

REMEMBER:

Your best assurance against accidents is a careful and responsible operator. If there is any portion of this manual or function you do not understand, contact your dealer or the ROTO-MIX plant.

SAFETY DECAL CARE

1. Keep safety decals and signs clean and legible at all times.
2. Replace safety decals and signs that are missing or have become illegible.
3. Replaced parts that displayed a safety sign should also display the current sign.
4. Safety decals or signs are available from your dealer or the ROTO-MIX manufacturing plant.
5. How to Install Safety Decals:
6. Be sure that the installation area is clean and dry.
7. Decide on the exact position before you remove the backing paper.
8. Remove the smallest portion of the split backing paper.
9. Align the decal over the specified area and carefully press the small portion with the exposed sticky backing in place.
10. Slowly peel back the remaining paper and carefully smooth the remaining portion of the decal in place.
11. Small air pockets can be pierced with a pin and smoothed out using the piece of decal backing paper.

FAILURE TO HEED MAY RESULT IN SERIOUS PERSONAL INJURY OR DEATH.

SPECIFICATIONS

DIMENSIONAL DATA - TRAILER MODELS

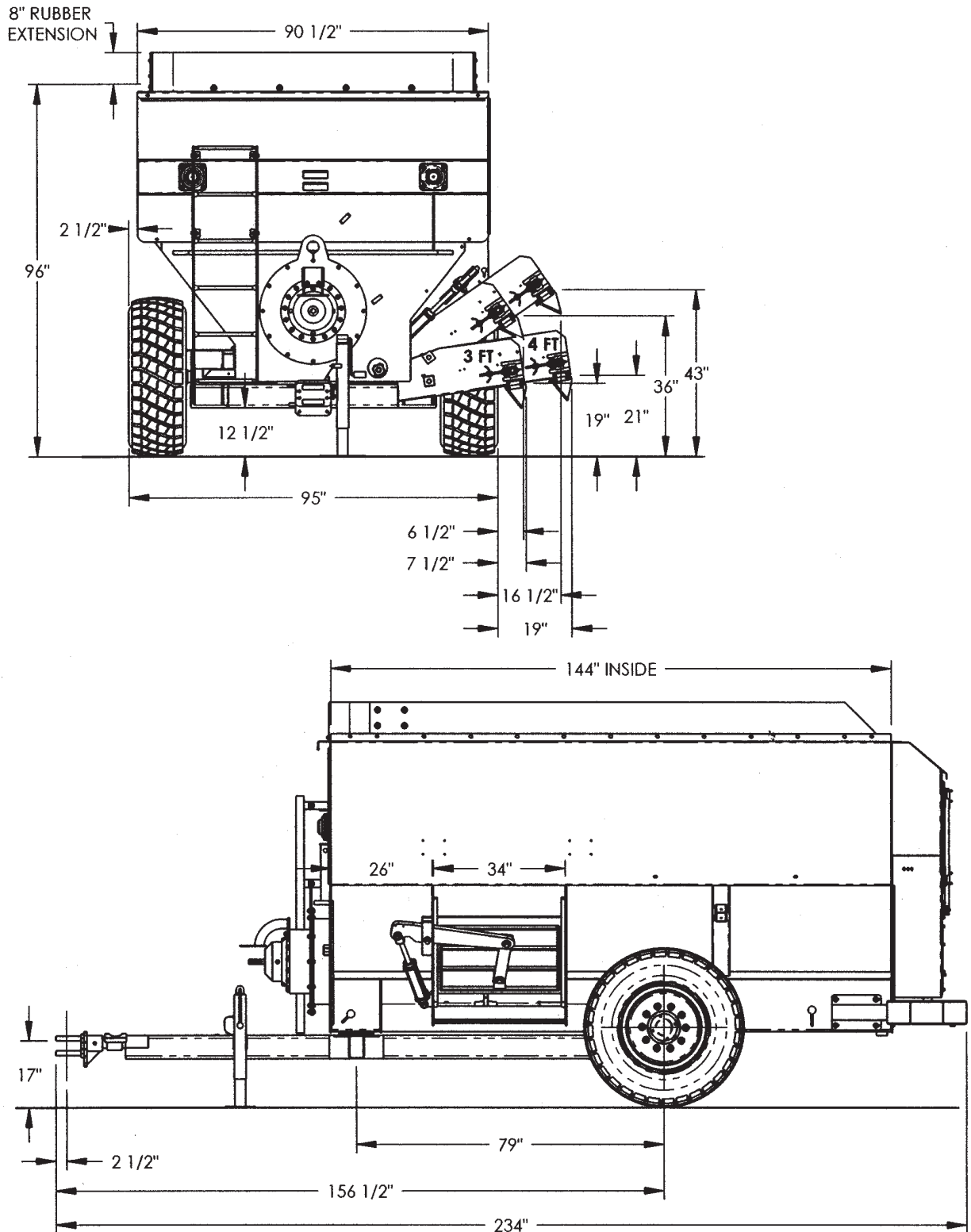

DIMENSIONAL DATA - TRUCK MODELS

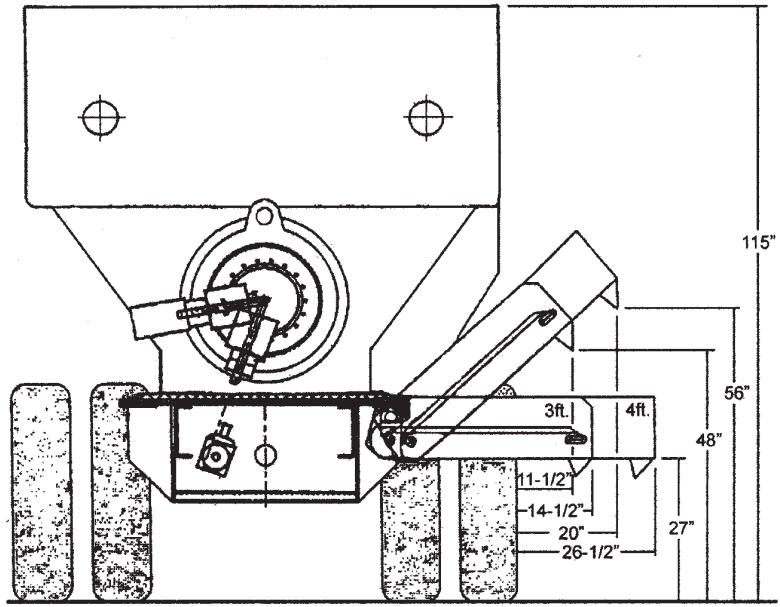

403-12 TRUCK MOUNT WITH WEIGH BARS ON
 38" TRUCK FRAME = 115" + RUBBER = 125"
 WITH LOAD CELLS ADD 4" TO HEIGHT

CONVEYOR 36" WIDE x 36" LONG - STANDARD
 CONVEYOR 36" WIDE x 48" LONG - OPTIONAL

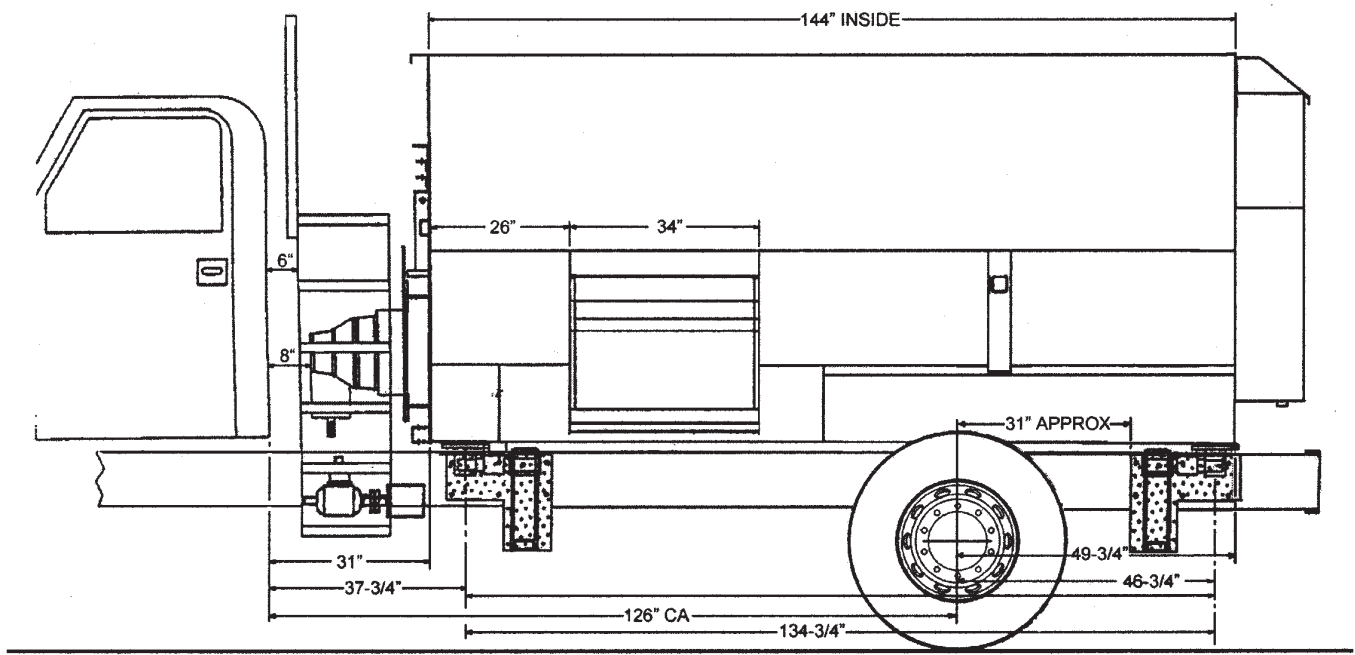

FEATURES

Dimension or Specification	403-12 Trailer	403-12 Truck
Weight w/Common Options	11,840	NA
Width, 3' Conveyor Up	94"	94"
Conveyor Length Options	3&4'	3&4'
Height, Trailer Standard Tires	96"	NA
Height, Truck 38" Frame	N/A	N/A
Discharge Conveyor Width	36"	36"
Bottom Thickness	1/4"	1/4"
Stainless Bottom Liner (std)	12 ga.	12 ga.
Upper Side Thickness	3/16"	3/16"
End Sheet Thickness Lower	All Sizes - 3/8" Front - 1/4" Rear	
End Sheet Thickness Upper	3/16"	3/16"
Hay Pro Rotor Diameter	34"	34"
Top Auger Diameter	24"	24"
Minimum Horsepower	80	
Capacity, Cubic Feet	400	400

PRE OPERATION

TRACTOR DRAWBAR

Set tractor drawbar as shown in figure 1.

CAUTION FAILURE TO SET DRAWBAR PROPERLY MAY CAUSE SHAFT TO OVER EXTEND AND SEPARATE OR BEND WHEN CORNERING OR TRANSPORTING RESULTING IN DEATH OR PERSONAL INJURY.

IMPORTANT: Drive components can be damaged from excessive speed. Under no circumstances should a feed mixer equipped with 540 RPM be operated by a tractor with 1000 RPM PTO.

Feed mixers are available with 540 RPM drive line. Match tractor PTO with the feed mixer drive line.

IMPORTANT: To prevent drive line damage, adjust tractor drawbar to recommended setting. Disengage tractor PTO before turning.

Remove clevis if equipped. Turn offset drawbar down.

Adjust drawbar length:

PTO SPEED
540 RPM
DIMENSION (A)
14 inches (356 mm)

ADJUST TRAILER HITCH CLEVIS

Mixer should be approximately level when attached to tractor.

Adjust clevis by changing hole location on trailer tongue.

PRE OPERATION CHECKLIST

1. Carefully study and understand this manual.
2. Do not wear loose-fitting clothing, which may catch in moving parts.
3. Always wear protective clothing *and* substantial shoes.
- 4.
- 5.

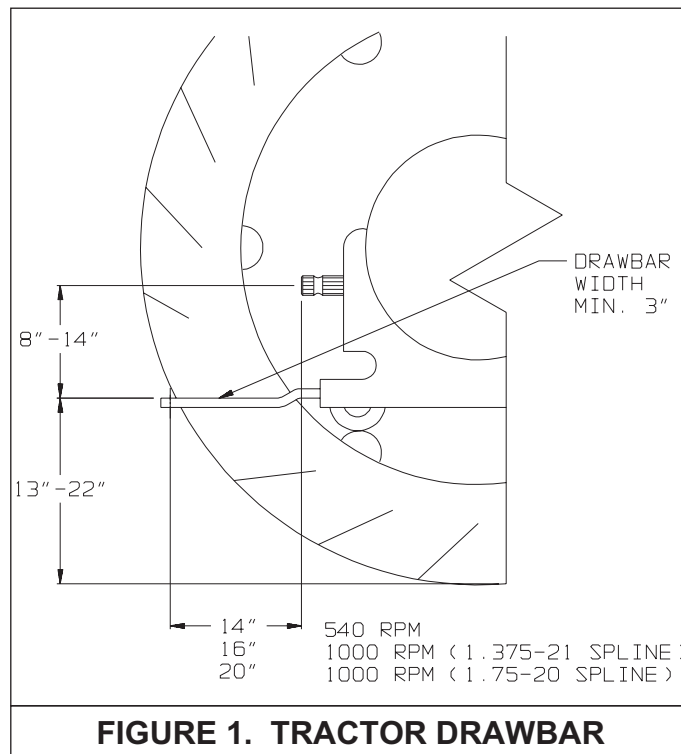

6. Keep wheel lug nuts or bolts tightened to specified torque.
7. Assure that agricultural implement tires are inflated evenly.
8. Give the unit a visual inspection for any loose bolts, worn parts or cracked welds, and make necessary repairs. Follow the maintenance safety instructions included in this manual.
9. Check to see that no obstructions are present in the mixer prior to start up.
10. Be sure that there are no tools lying on or in the mixer/feeder.
11. Do not use the unit until you are sure that the area is clear, especially children and animals.
12. Because it is possible that this mixer/feeder may be used in dry areas or the presence of combustibles, special precautions should be taken to prevent fires and fire fighting equipment should be readily available.
13. Don't hurry the learning process or take the unit for granted. Ease into it and become familiar with your new mixer/feeder.
14. Practice operation of your mixer/feeder and its attachments. Completely familiarize yourself and other operators with its operation before using.

15. Securely attach to towing unit. Use a high strength, appropriately sized hitch pin with a mechanical retainer.
16. Do not allow anyone to stand between the tongue or hitch and the towing vehicle when backing up to the mixer/feeder.

TRACTOR HYDRAULIC SYSTEM RECOMMENDATIONS

10 GPM Minimum 15 GPM Maximum
1200 to 1600 PSI Operating Range
Hydraulic system should be self purging.

TRAILER OPERATION

PTO ENGAGEMENT

This mixer is designed with 540 PTO. Do Not Operate a 540 rpm mixer with 1000 rpm tractor PTO.

Avoid high speed sudden engagement of the mixer. Doing so may cause the shear pin to shear.

CORNERING

Sharp cornering with the PTO engaged is not recommended. If it is necessary to mix when cornering, it should be done at reduced speeds and on wide corners only.

LOADING INSTRUCTIONS & PRECAUTIONS

- A. Do not add side board extensions to the mixer.
- B. The conveyor begins to move as it is lowered into position, fully engaging after the lifting cylinders have been fully extended.

DISCHARGING FEED

For Tractors With Hydraulic Lift Option:

The conveyor motor and conveyor tilt are sequenced so when the tractor's hydraulic control lever is moved one way, the conveyor will extend downward and the conveyor motor will begin to operate, fully engaging after the cylinder is fully retracted.

The discharge door is operated using separate hydraulic controls.

When through feeding, close the discharge door, clear conveyor of all remaining feed, and extend hydraulic cylinder to lift conveyor.

For Tractors With Fixed Conveyor Option:

The conveyor motor is actuated using one set of hydraulic controls while the discharge door is operated using a separate set of hydraulic controls.

SCALE SWING MOUNT

The scale head is mounted to a swing arm. The swing arm is designed to allow scale head viewing from either side of the mixer or from the tractor just by rotating the scale arm before loading or unloading starts.

SCALE SYSTEM

Refer to the operation book supplied with the scale indicator head.

HIGHWAY AND TRANSPORT OPERATION

1. Adopt safe driving practices:
2. Keep the brake pedals latched together at all times. Never use independent braking with machine in tow as loss of control and/or upset of unit can result.
3. Always drive at a safe speed relative to local conditions and ensure that your speed is low enough for an emergency stop to be safe and secure. Keep speed to a minimum.
4. Reduce speed prior to turns to avoid the risk of overturning.
5. Avoid sudden uphill turns on steep slopes.
6. Always keep the tractor or towing vehicle in gear to provide engine braking when going downhill. Do not coast.
7. Do not drink and drive.
8. Comply with state and local laws governing highway safety and movement of farm machinery on public roads.
9. Use approved accessory lighting flags and necessary warning devices to protect operators of other vehicles on the highway during daylight and nighttime transport.
10. The use of flashing amber lights is acceptable in most localities. However, some localities prohibit their use. Local laws should be checked for all highway lighting and marking requirements.
11. When driving the tractor and mixer/feeder on the road or highway under 20 MPH (40 KPH) at night or during the day, use flashing amber warning lights and a slow moving vehicle (SMV) identification emblem.
12. Plan your route to avoid heavy traffic.
13. Be a safe courteous driver. Always yield to oncoming traffic in all situations, including narrow bridges, intersections, etc.
14. Be observant of bridge loading ratings. Do not cross bridges rated lower than the gross weight at which you are operating.
15. Watch for obstructions overhead and to the side while transporting.

16. Always operate mixer/feeder in a position to provide maximum visibility at all times. Make allowances for increased length and weight of the mixer/feeder when making turns, stopping the unit, etc.

LIGHTING AND MARKING

It is the responsibility of the customer to know the lighting and marking requirements of the local highway authorities and to install and maintain the equipment to provide compliance with the regulations. Add extra lights when transporting at night or during periods of limited visibility.

TRUCK OPERATION

TRUCK

For truck operation and limitations, refer to the Truck's owner's manual.

SCALE SYSTEM

Refer to the operation Book supplied with the scale indicator head.

FOLLOWING OPERATION:

Following operation, stop the truck, set the brakes, disengage the PTO and all power drives, shut off the engine and remove the ignition keys.

Store the unit in an area away from human activity.

Do not park equipment where it will be exposed to livestock for long periods of time. Damage and livestock injury could result.

Do not permit children to play on or around the stored unit.

Make sure parked machine is on a hard, level surface and engage all safety devices.

Wheel chocks may be needed to prevent unit from rolling.

LOADING INSTRUCTIONS & PRECAUTIONS

- A. Do not add side board extensions to the mixer.
- B. The conveyor begins to move as it is lowered into position, fully engaging after the lifting cylinder have been fully extended.

DISCHARGE FEED

For Tractors With Hydraulic Lift Operation:

The conveyor motor and conveyor tilt are sequenced so when the tractor's hydraulic control lever is moved one way, the conveyor will extend downward and the conveyor motor will begin to operate, fully engaging after the cylinder is fully retracted.

The discharge door is operated using separate hydraulic controls.

When through feeding, close the discharge door, clear conveyor of all remaining feed and extend hydraulic cylinder to lift conveyor.

For Tractors With Fixed Conveyor Option:

The conveyor motor is actuated using one set of hydraulic controls while the discharge door is operated using a separate set of hydraulic controls.

SCALE SWING MOUNT

The scale head is mounted to a swing arm. The swing arm is designed to allow scale head viewing from either side of the mixer or from the tractor just by rotating the scale arm before loading or unloading starts.

SCALE SYSTEM

Refer to the operation book supplied with the scale indicator head.

HIGHWAY AND TRANSPORT OPERATION

1. Adopt safe driving practices.
2. Always drive at a safe speed relative to local conditions and ensure that your speed is low enough for an emergency stop to be safe and secure. Keep speed to a minimum.
3. Reduce speed prior to turns to avoid the risk of overturning.
4. Avoid sudden uphill turns on steep slopes.
5. Always keep the truck in gear to provide engine braking when going downhill. Do not coast.
6. Do not drink and drive.
7. Comply with state and local laws governing highway safety and movement of farm machinery on public roads.
8. Use approved accessory lighting flags and necessary warning devices to protect operators of other vehicles on the highway during daylight and nighttime transport.
9. The use of flashing amber lights is acceptable in most localities. However, some localities prohibit their use. Local laws should be checked for all highway lighting and marking requirements.
10. When driving the truck and mixer/feeder on the road or highway under 20 MPH at night or during the day, use flashing amber warning lights and a slow moving vehicle (SMV) identification emblem.
11. Plan your route to avoid heavy traffic.

12. Be a safe courteous driver. Always yield to oncoming traffic in all situations, including narrow bridges, intersections, etc.
13. Be observant of bridge loading ratings. Do not cross bridges rated lower than the gross weight at which you are operating.
14. Watch for obstructions overhead and to the side while transporting.
15. Make allowances for increased length and weight of the mixer/feeder when making turns, stopping the unit, etc.

LIGHTING AND MARKING

It is the responsibility of the customer to know the lighting and marking requirements of the local highway authorities and to install and maintain the equipment to provide compliance with the regulations. Add extra lights when transporting at night or during periods of limited visibility.

MAINTENANCE

⚠ WARNING ALWAYS DISCONNECT OR DISENGAGE POWER TAKE OFF AND REMOVE KEYS FROM TRACTOR OR TRUCK BEFORE CLEANING, ADJUSTING, LUBRICATION OR SERVICING THIS MACHINE. FAILURE TO HEED MAY RESULT IN SERIOUS PERSONAL INJURY OR DEATH.

The lowered position of the chute is limited by the mechanical interference of the bottom of the chute and the bottom of the conveyor.

READ THE FOLLOWING BEFORE WELDING ON THIS MIXER/FEEDER

When welding on your mixer/feeder, do not allow the current to flow through the ball bearings or the roller chains. Ground directly to the item being welded.

Always disconnect the scale instrumentation from the weigh bars or load cells and the power source. Be sure the current does not pass through weigh bars or load cells or scale indicator. The alternator should always be disconnected if the mixer/feeder is not disconnected from the towing vehicle.

LUBRICATION - TRAILER MOUNTS

⚠ WARNING

ALWAYS DISCONNECT OR DISENGAGE POWER TAKE OFF AND REMOVE KEYS FROM TRACTOR OR TRUCK BEFORE CLEANING, ADJUSTING, LUBRICATING OR SERVICING THIS MACHINE. FAILURE TO HEED MAY RESULT IN SERIOUS PERSONAL INJURY OR DEATH.

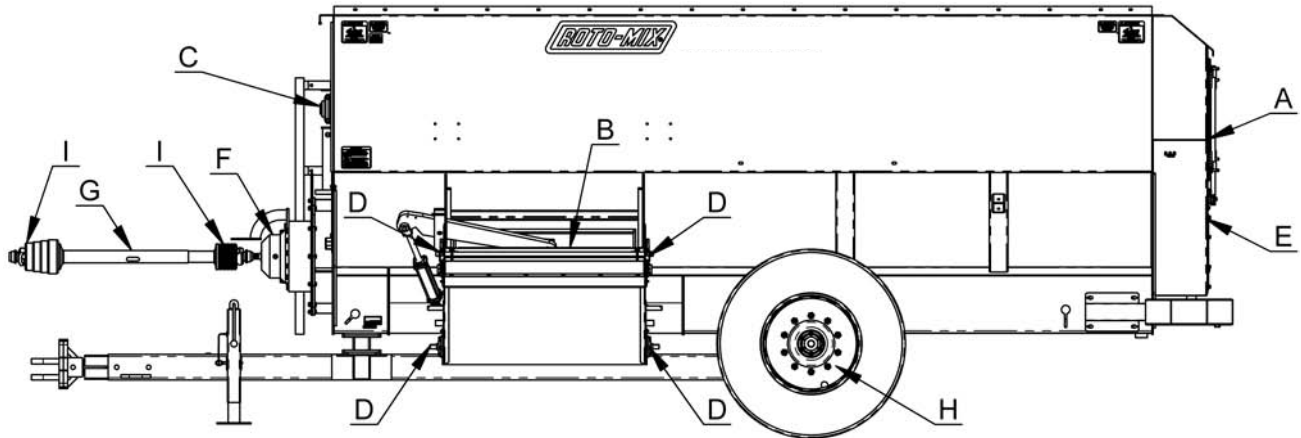

LCTN	ITEM	LUBRICATION	INTERVAL
A	Rear Drive Oil Bath	SAE 30. Approximately 10 gallon capacity.	Check every 60 days. Keep filled to sight plug. Change if contaminated.
B	Conveyor Chain	Light Weight Oil	Brush On lightly every 40 Hours of operation
C	Front Bearings	Standard All Purpose Grease	Every 100 hrs.
D	Conveyor Bearings	Standard All Purpose Grease	One pump every 8 hours of operation
E	Bearings In Rear Drive	Standard All Purpose Grease	Three pumps every 100 hrs. for each zerk in grease bank.
F	Gearbox	Mobil Delvac Synthetic Gear Oil 75W-90	Prior to operation, remove the upper most plug and replace with vent plug provided. After first 100 Hrs. of operation, drain the oil. Flush gear case with an approved non flammable, non toxic solvent and refill with oil. There after oil should be changed every 2000 Hrs. or 12 months.
G	PTO Shaft	Standard All Purpose Grease	Every 16 Hrs. IMPORTANT: AT EACH LUBRICATION MAKE SURE THE PTO SHAFT SLIDES IN AND OUT FREELY. FAILURE OF THE SHAFT TO SLIDE FREELY WILL RESULT IN DRIVE TRAIN DAMAGE.
H	Wheel Bearings	Pack With Lithium Base Grease	Pack Every 12 Months
I	U-Joint	Standard All Purpose Grease	Every 10-20 hrs.

LUBRICATION - TRUCK MOUNT

⚠ WARNING

ALWAYS DISCONNECT OR DISENGAGE POWER TAKE OFF AND REMOVE KEYS FROM TRACTOR OR TRUCK BEFORE CLEANING, ADJUSTING, LUBRICATING OR SERVICING THIS MACHINE. FAILURE TO HEED MAY RESULT IN SERIOUS PERSONAL INJURY OR DEATH.

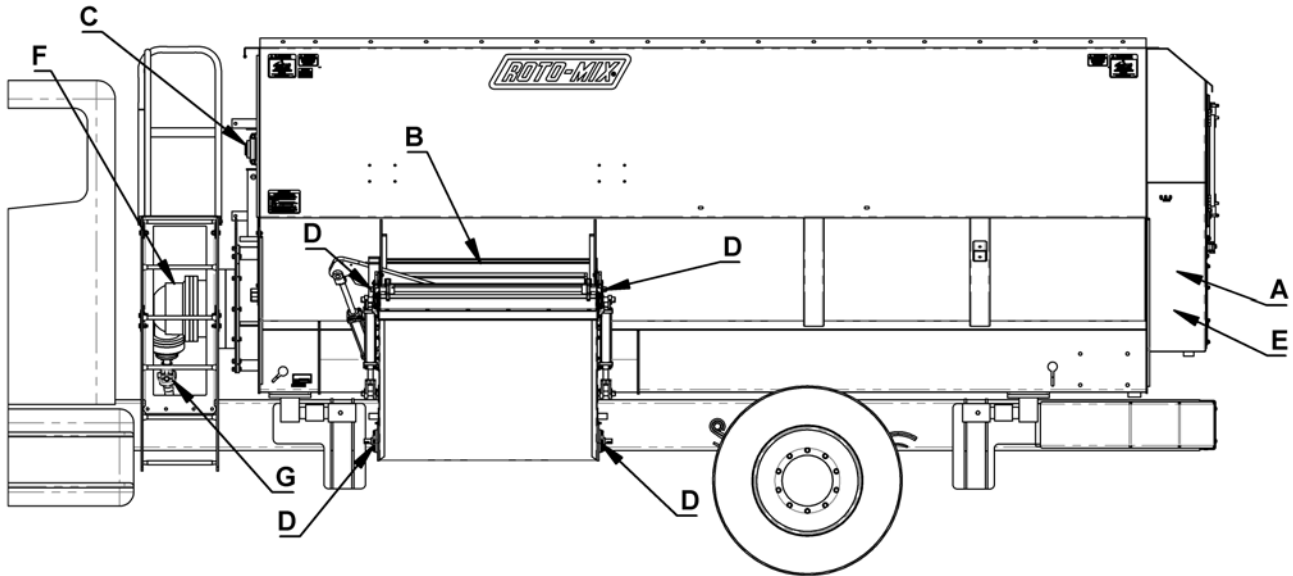

LOCATION	ITEM	LUBRICATION	INTERVAL
A	Rear Drive Oil Bath	SAE 30. Approximately 10 Gallon Capacity.	Check every 60 Days. Keep filled to sight plug. Change if contaminated.
B	Conveyor Chain	Light Weight Oil	Brush on lightly every 40 hours of operation.
C	Front Bearings	Standard All Purpose Grease	Every 100 hrs.
D	Conveyor Bearings	Standard All Purpose Grease	One pump every 8 hours of operation.
E	Bearings in Rear Drive	Standard All Purpose Grease	Three pumps every 100 hrs. for each zerk in grease bank.
F	Gearbox	Mobil Delvac Synthetic Gear Oil 75W-90	Prior to operation, remove the upper most plug and replace with vent plug provided. After first 100 Hrs. of operation, drain the oil. flush gear case with an approved non flammable, non toxic solvent and refill with oil. There after oil should be changed every 2000 Hrs. or 12 months.
G	U-Joint	Standard All Purpose Grease	Every 10-20 hrs.
	Truck Chassis	See Manufacturer's Recommendations.	

TROUBLESHOOTING

⚠ WARNING

ALWAYS DISCONNECT OR DISENGAGE POWER TAKE OFF AND REMOVE KEYS FROM TRACTOR OR TRUCK BEFORE CLEANING, ADJUSTING, LUBRICATING OR SERVICING THIS MACHINE. FAILURE TO HEED MAY RESULT IN SERIOUS PERSONAL INJURY OR DEATH.

NOTE: CHART NOT ALL INCLUSIVE OF PROBLEMS. CONTACT DEALERSHIP FOR ASSISTANCE.

PROBLEM	POSSIBLE CAUSE	POSSIBLE REMEDY
Excessive Shearing Of Power shaft Shear Pin (Optional)	High Speed Engagement Of PTO Or Conveyor.	Decrease RPM Of The Engine Before Engaging PTO Or Lowering Discharge Chute On Trailer Mixers.
	Excessive Loads.	Refer To General Information About Machine Loading
Vibration Or Growling In Rear Structure	Drive Sprockets Out Of Line	Check And Realign
	Universal Joints Out Of Alignment.	Check And Realign
	Worn Out Bearing.	Replace Bearing.
Chains Jumping Sprocket Teeth	Idler Springs Loose.	Adjust Idlers As Instructed On Page .
	Drive Sprockets Out Of Line	Check And Realign
	Worn Sprocket Teeth.	Replace Sprocket.
Drive Chains Breaking	Sprocket Misalignment	Align Sprockets
	Usually Causes Side Bar Breakage Due To Chain Riding Up On Sprocket Teeth.	See Possible Remedies To “chains Jumping Sprocket Teeth” Above
	Excessive Loads.	Refer To General Information About Machine Loading
Excessive Bearing Failure	Improper Lubrication	Refer To Lubrication Chart.
	Contamination	Check Seal
	Excessive Loads.	Refer To General Information About Machine Loading

OPTIONAL COMPONENT INSTALLATION

SCALE MOUNTING (TRUCK MOUNT ONLY)

The primary scale indicator is mounted to the right hand side of the driver seat on an adjustable pedestal. The pedestal is custom fit to the truck and is bolted to the floor of the cab and supported with braces to avoid vibration. The pedestal can be adjusted to provide easy viewing and access from the drivers seat.

Auxiliary indicator mounts are also supplied on the right and left hand side of the mixer to provide for mounting of an optional Remote Indicator on either or both sides of the mixer. These mounts allow the indicator to be rotated for easy viewing.

The Truck mixer is initially provided with mounting brackets matching the scale indicator purchased. If in the future a different scale indicator is purchased, new mounting brackets will be needed.

INSTALLING BATTERY ON MIXER (TRAILER MOUNT ONLY)

NOTE: Tractor socket shipped with mixer is not used when a battery is installed on the mixer.

1. Open cover on battery box .
2. Position 12 VDC automotive battery on battery shelf.
3. Connect to battery positive and negative terminals.
4. Connect scale head power cord, see figure 2. Cord to run through side of battery box.

5. Use a nylon strap to anchor battery to battery shelf (not supplied).

6. Close cover and strap down.

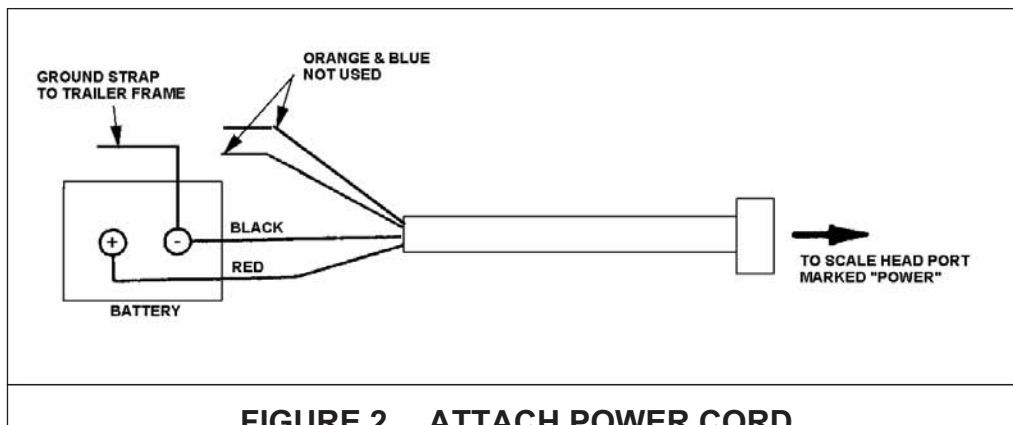

FIGURE 2. ATTACH POWER CORD

This page Intentionally Blank

REPAIR PARTS

Arm Rest And Scale Indicator assemblies	28
Fluid Tech Hydraulic Valve	29
Hydraulic Pump	30
Oil Reservoir	31
Hydraulic Schematic, Straight Door	32
Discharge Wire Schematic.	33
PTO, Gearbox & Extensions	34
Augers & Rotor	36
403-12 Standard Drive Assembly	38
403-12 Heavy Drive Assembly	40
Oil Bath Door Group	42
Discharge Door & Extension	44
Discharge Conveyor	46
403 Conveyor Mount Kit - Fixed.	48
Trailer Hydraulic Kit - Fixed Conveyor	49
403 Conveyor Mount Kit - Hyd. Lift	50
Trailer Hydraulic Kit - Hyd Conveyor	51
Trailer, Battery Box & Weigh Bars	52
Hub Assembly & Wheel Assembly.	54
Truck Fenders	56
Ladder, Rails, & Platform - Truck	58
Scale Indicator Arm Assembly	60
PTO Shaft - 540 Rpm.	62

ARM REST AND SCALE INDICATOR ASSEMBLIES

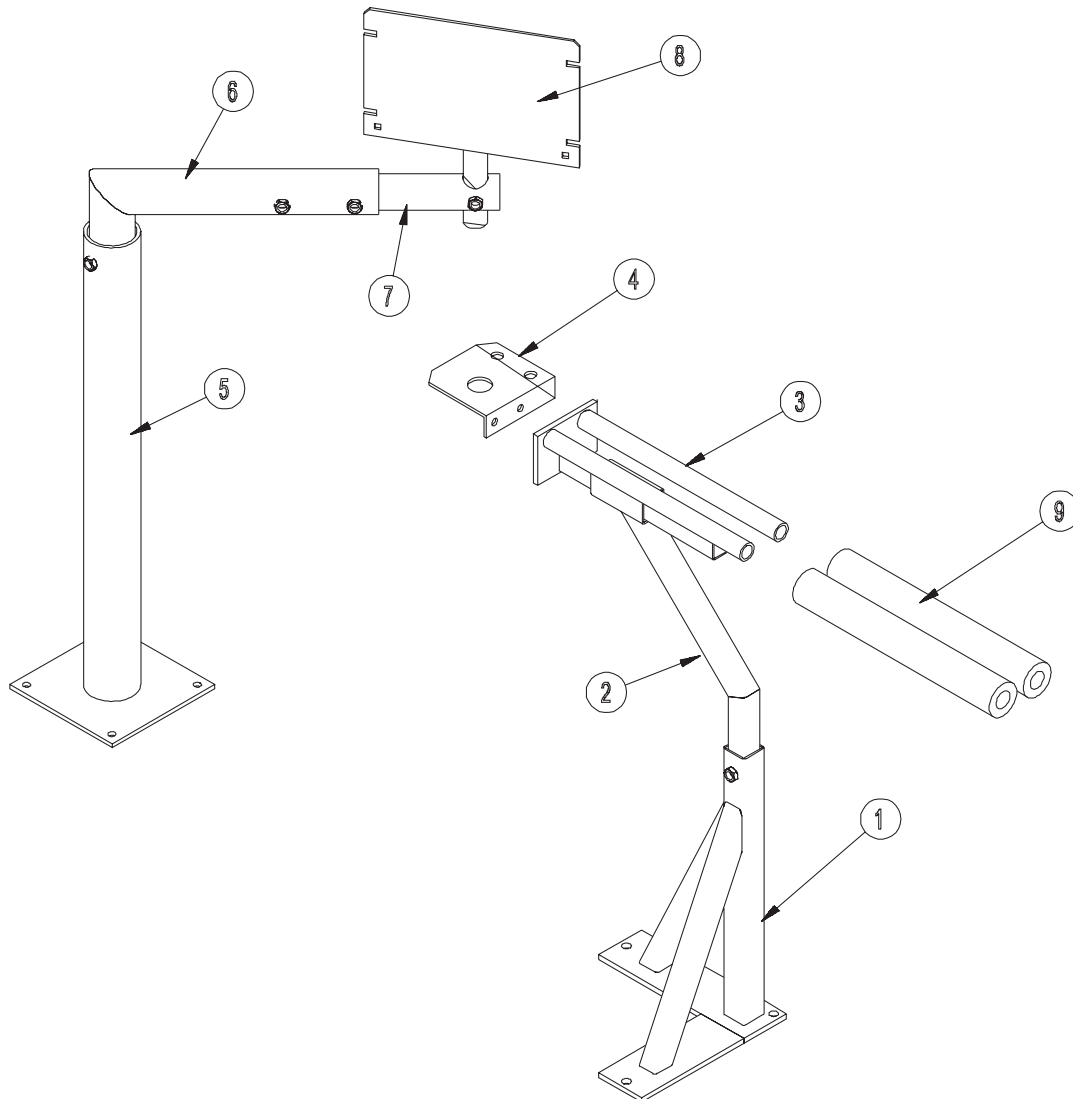

KEY	PART NO.	DESCRIPTION	QTY.
1	872262	Arm Rest Stand WA	1
2	872263	Arm Rest Goose Neck WA	1
3	872264	Arm Rest WA	1
4	188226	Electric Feeder Control Bracket	1
5	871087	Truck Scale Indicator Base WA	1
6	871095	Truck Scale Indicator Mount WA	1
7	871103	Indicator Extension Tube WA	1
8	871111	Truck Scale Indicator Swivel WA	1
9	185930	Arm Rest Pad 12"	2

FLUID TECH HYDRAULIC VALVE

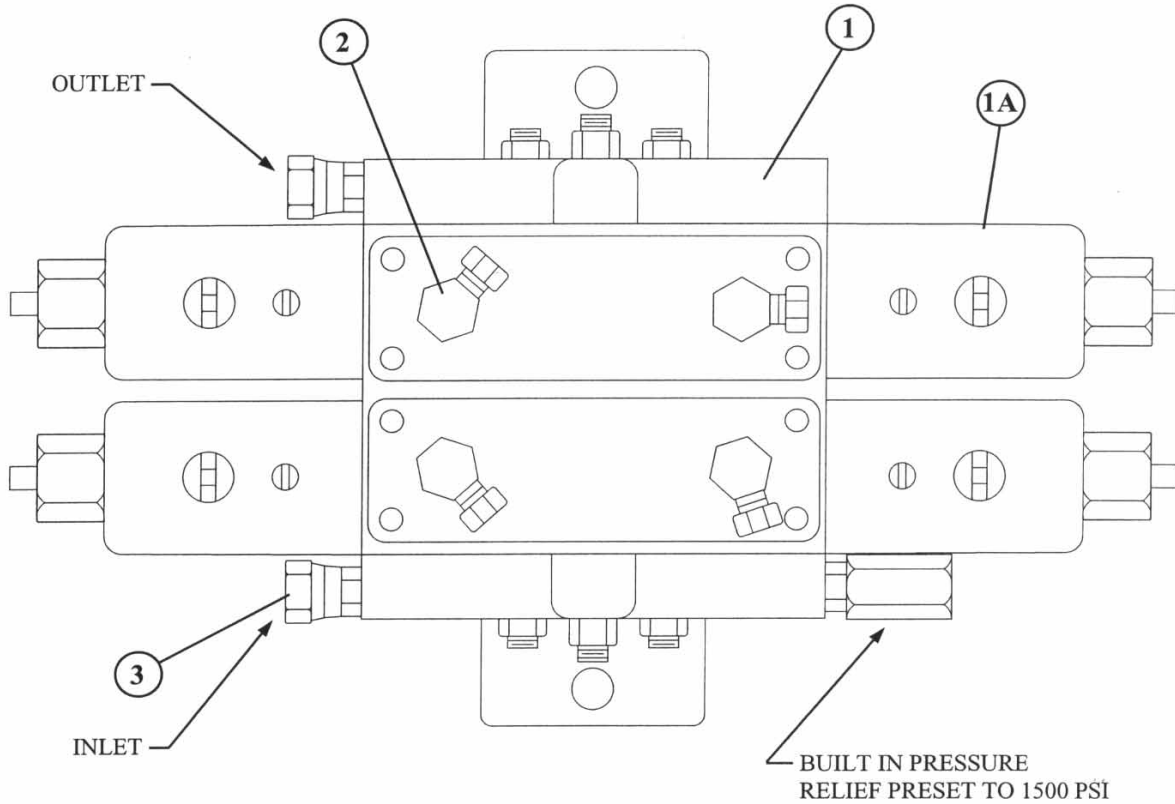

KEY	PART NO.	DESCRIPTION	QTY.
1	362209	Fluid Tech Hydraulic Valve	1
1A	362206	12V Sing MV5 Hyd MVSR 1500-10-50-12-TD	2
2	368030	9/16" MOR x 3/8" FPSW 90°	4
3	368115	9/16" MOR x 3/8" FPSW Strt. Adp	2
4	362221	MV5-A Lock Valve, 9/16 MOR	1

HYDRAULIC PUMP

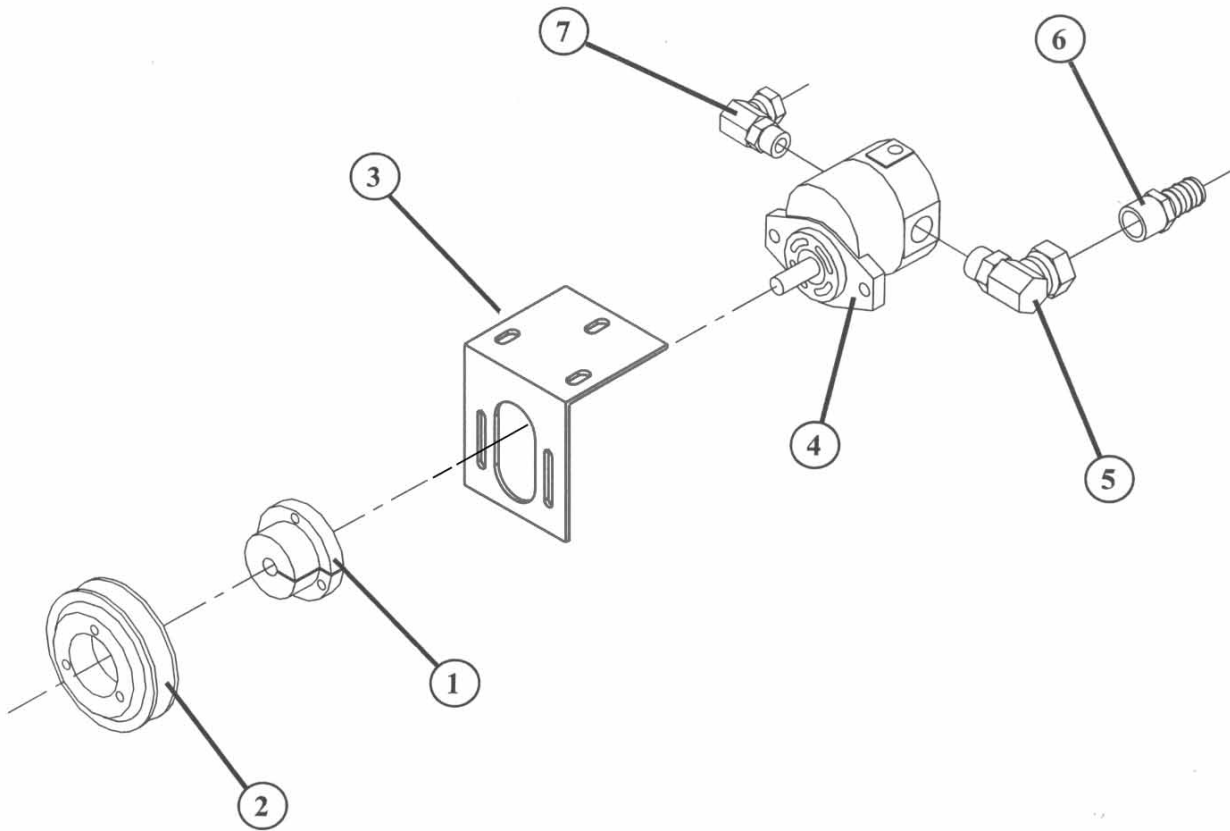

KEY	PART NO.	DESCRIPTION	QTY.
1	336008	SH Bushing 1/2" Bore	1
2	324040	1B x 4.0" SH Belt Sheave	1
3	189053	Hydraulic Pump Bracket	1
4	362017	Hydraulic Pump	1
5	368050	3/4" FP x 7/8" MOR 90° Swivel	1
6	368512	3/4" MP x 3/4" Hose Barb	1
7	368040	3/8" FP x 3/4" MOR 90° Swivel	1

OIL RESERVOIR

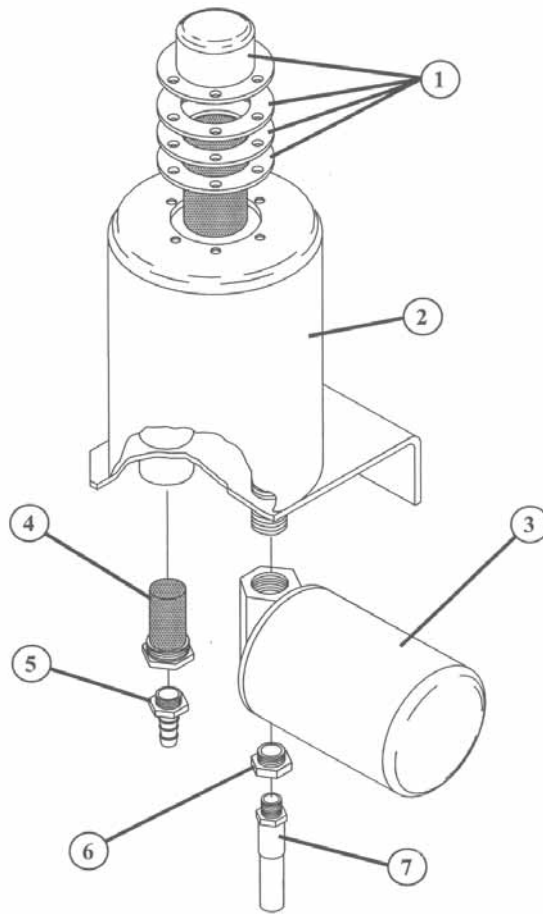

KEY	PART NO.	DESCRIPTION	QTY.
1	362550	Filler Cap	1
2	870477	Oil Reservoir Weldment	1
3	362400	Filter Assembly	1
4	362504	Suction Screen	1
5	368512	3/4" Hose Barb	1
6	310815	3/4" To 3/8" Reducer Bushing	1
7	781059	3/8" X 20" Hyd. Hose Assembly (3/8" MP Ends)	1

HYDRAULIC SCHEMATIC, STRAIGHT DOOR

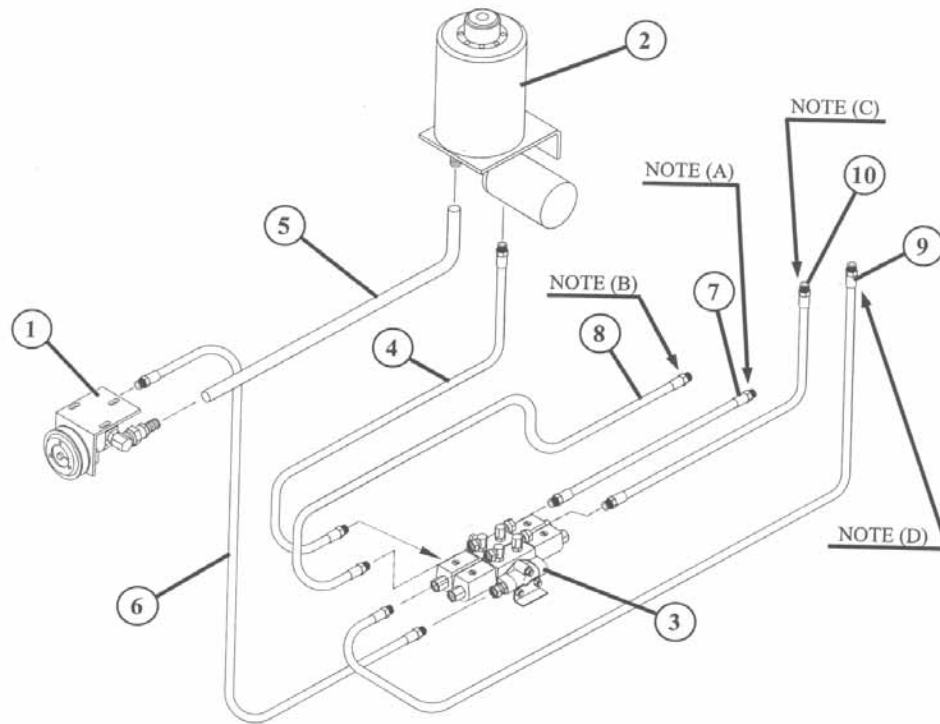

NOTE A: CONNECT TO SPOUT CYLINDER BASE

NOTE B: CONNECT TO SPOUT CYLINDER ROD END

NOTE C: CONNECT TO DOOR CYLINDER BASE

NOTE D: CONNECT TO DOOR CYLINDER ROD END

KEY	PART NO.	DESCRIPTION	QTY.
1	780064	Hydraulic Pump Assembly	1
2	780205	Reservoir Assembly	1
3	780123	Hydraulic Valve Assembly	1
4	781059	Hyd. Hose Asm. 3/8" X 20" w/3/8" MP Ends	1
5	184291	Hyd. Hose Asm. 3/4" X 144" (Suction Line)	1
6	781073	Hyd. Hose Asm. 3/8" X 144" w/3/8" MP Ends	1
7	781066	Hyd. Hose Asm. w/3/8" MP & 1/4" MP Ends	1
8	781069	Hyd. Hose Asm. w/3/8" MP & 1/4" MP Ends	1
9	781061	Hyd. Hose Asm. w/3/8" MP Ends	1
10	781098	Hyd. Hose Asm. w/3/8" MP Ends	1

DISCHARGE WIRE SCHEMATIC

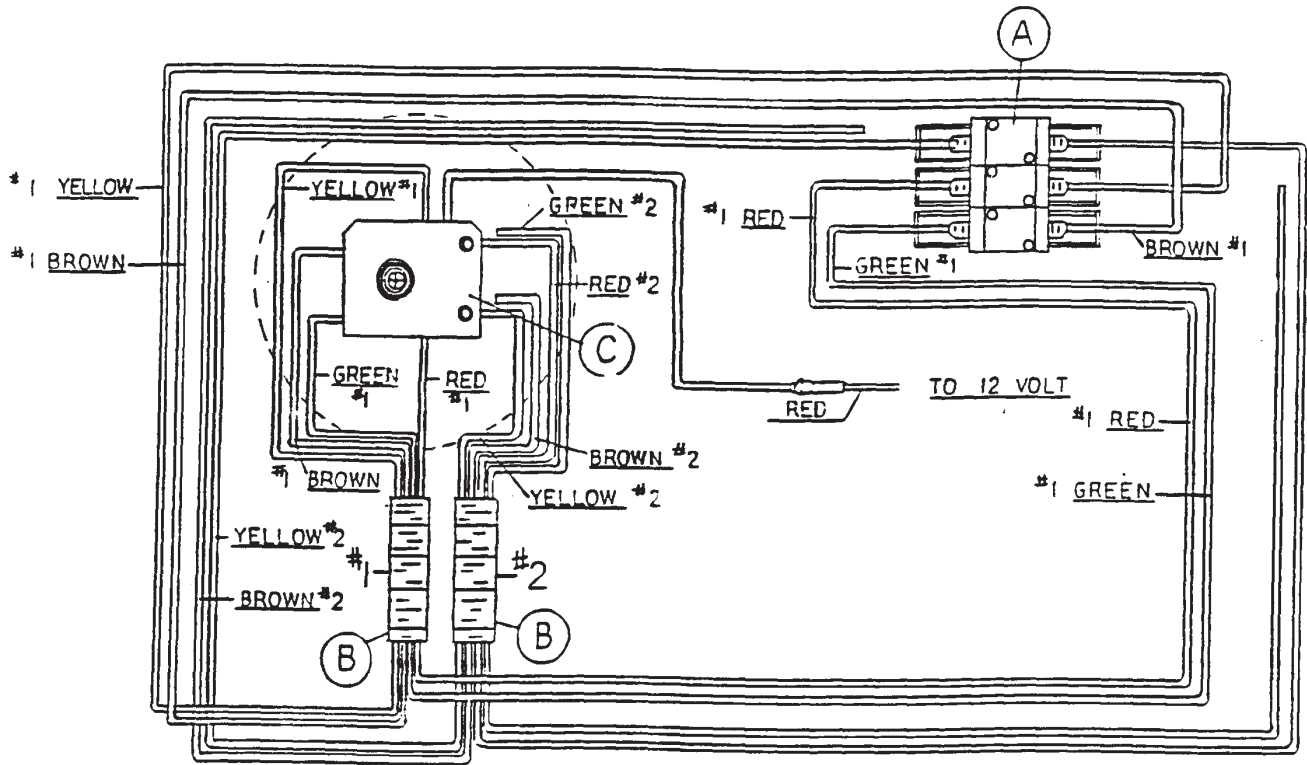

KEY	PART NO.	DESCRIPTION	QTY.
A	780123	MV5 Hyd, Control Valve Assembly	1
B	781055	Truck to Mixer Wire Assembly	2
	781056	Truck Push Button Switch Wire Assembly	2
C	188226	Feeder Electric Control Bracket	1
	357705	Joystick	1

PTO, GEARBOX & EXTENSIONS

KEY	PART NO.	DESCRIPTION	QTY.
1	171597	403 Top Extension Rubber - 10" x 130"	2
2	171426	Rubber Ext. End - 120"	1
3	344053	Gearbox 2250 MN/36/1 3/8 Input	1
4	875382	Gearbox PTO Shield WA	1
5	171336	Gear Box Mount Plate 2250 -27 1/2"	1
6	400210	Hex Nut #5 Pltd 5/8 / 11	15
7	402010	Spring Lock Washer Med 5/8"	15
8	405703	1/2" x 1 1/4" HHCS	12
9	402008	Lock Washer, Pltd., 1/2"	12
10	400208	Hex Nut #5 Pltd., 1/2"-13	12
11	405768	5/8"-11x 7" HHCS	2
12	171427	Ext. Mnt. Angle - 54"	1
13	405656	HHCS #5 Pltd 3/8-16 x 1 3/4	8
14	407041	Carg Bolt #5 Pld 3/8-16 x 1 1/4	32
15	401106	Hex Nyloc Nut 5 Pltd 3/8-16	48
16	402606	Fender Washer Pltd 3/8 x 1 1/2	48
17	402406	Flat Washer Med Pltd 3/8	48
18	338035	Dr. Shaft W2400 540x540 SC5 (See Pg 62)	1
19	780601	PTO Shield	1
20	405767	HHCS #5 Pltd 5/8-11 x 6 1/2	13

(\$ ' 51 ; 9FG/ ' FCHCF

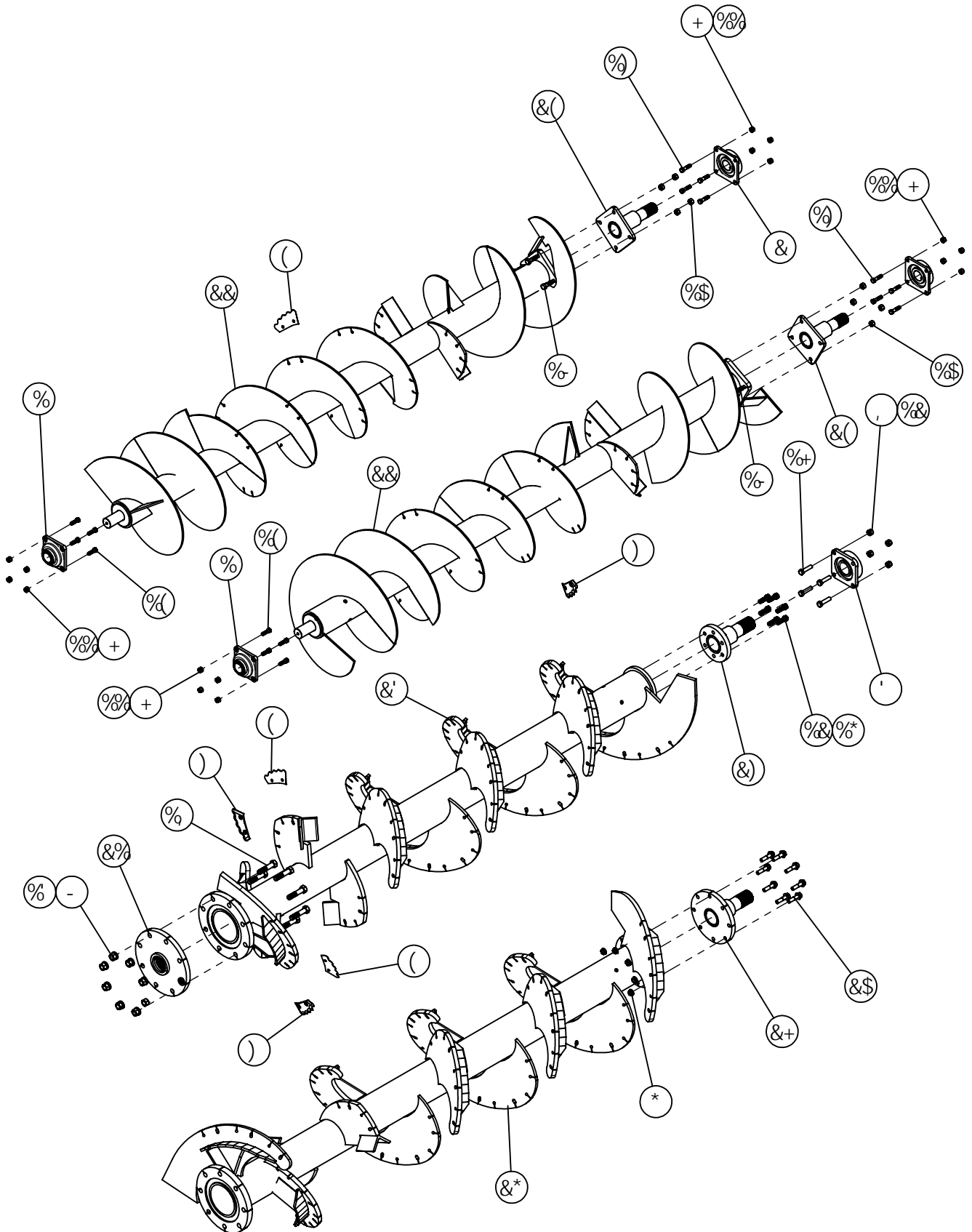

(\$ ' 5I ; 9FG/ ' FCHCF

#PA	D5FH	8 9G7 F ðHC B	'E HM'
%	' (\$(' -	695F-B; ž&!#%*": @5B; 9'A C I B H	&
&	' (\$)(\$	695F-B; ž&!%#&"(!6@H: @5B; 9ž65@@ 'A G !(\$	&
'	' (\$)(,	695F-B; ž' ""(!6@H: @5B; 9ž65@@ 'A G !(,	%
(' ,)\$\$*	5I ; 9F ?B ÷ 9, "ž@9: H<5B8	'
)	' ,)\$\$-	5I ; 9F ?B ÷ 9, "žF ÷ <H<5B8	'
*	(\$\$%&*	<9L 'B I Hž' #('!\$'G9FFF5H98': @5B; 9'D@B	,
+	(\$\$&%\$	<YI 'B i h) #, '!'%& .) 'D@B'	%*
,	(\$\$&%&	<9L 'B I Hž' #('!'\$' .) 'D@B	(
-	(\$\$&%*	<9L 'B I Hž%'! , .) 'D@B'	,
%\$	(\$\$-%&	<9L '7 H F '@ 7 B I Hž' #('!'\$' .) 'D@B'	,
%%	(\$&\$%\$	GDF-B; '@ 7 ? 'K 5G<9F') #, "'D@B	%*
%&	(\$&\$%&	GDF-B; '@ 7 ? 'K 5G<9Fž' #('"'D@B	%\$
%	(\$&\$%*	GDF-B; '@ 7 ? 'K 5G<9Fž%"'D@B	,
%(\$	(\$)+(\$	<<7 Gž) #, '!'%&! '&' .) 'D@B	,
%)	(\$)+)*	<<7 Gž) #, '!'%&! '&%'#&' .) 'D@B	,
%*	(\$)+,%	<<7 Gž' #('!'\$'! '&%'#&' .) 'D@B	*
%+	(\$)+,'	<<7 Gž' #('!'\$'! ' .) 'D@B'	(
%	(\$), '(<<7 Gž%'! '('%#&' .) 'D@B	,
%-	(\$*(,%	<<7 Gž' #('!'\$'! '&%'#&' . , 'D@B	,
&\$	(\$+-(<<7 Gž' #('!'\$'! ' "'G9FFF5H98': @5B; 9' . , 'D@B	,
&%	, +)' *%	&&) '\$8F ð 9<I 6'K "5"	%
&&	, +)(' ((\$' !%& HC D'5I ; 9F 'K "5"	&
&'	, +)(')	(\$' 'FC HC F 'K 5 'ff'!6C @Ł	%
&(, +)((&	(\$' '5I ; 9F 'G<5: H: @5B; 9'K 5	&
&)	, +)(('	(\$' 'FC HC F 'F95F 'G<5: HK 5 'ff'!6C @Ł	%
&*	, +))&-	(\$' 'FC HC F 'K 5 'fj'!6C @Ł	%
&+	, +))' &	(\$' 'FC HC F 'F95F 'G<5: HK 5 'fj'!6C @Ł	%
	*+\$%&)	(\$' 'FC HC F '?B ÷ 9? #f#Wi XYg_bj Yg/ \Xk 'fcf'dUXX'YgŁ	
	+\$%&	(\$' 'FC HC F '?B ÷ 9? #f#Wi XYg_bj Yg/ \Xk 'Zcf' 'dUXX'YgŁ	
	*+\$%&,&	(\$' 'HC D'5I ; 9F '?B ÷ 9? #f	

403-12 STANDARD DRIVE ASSEMBLY
(670129 STANDARD DRIVE KIT)

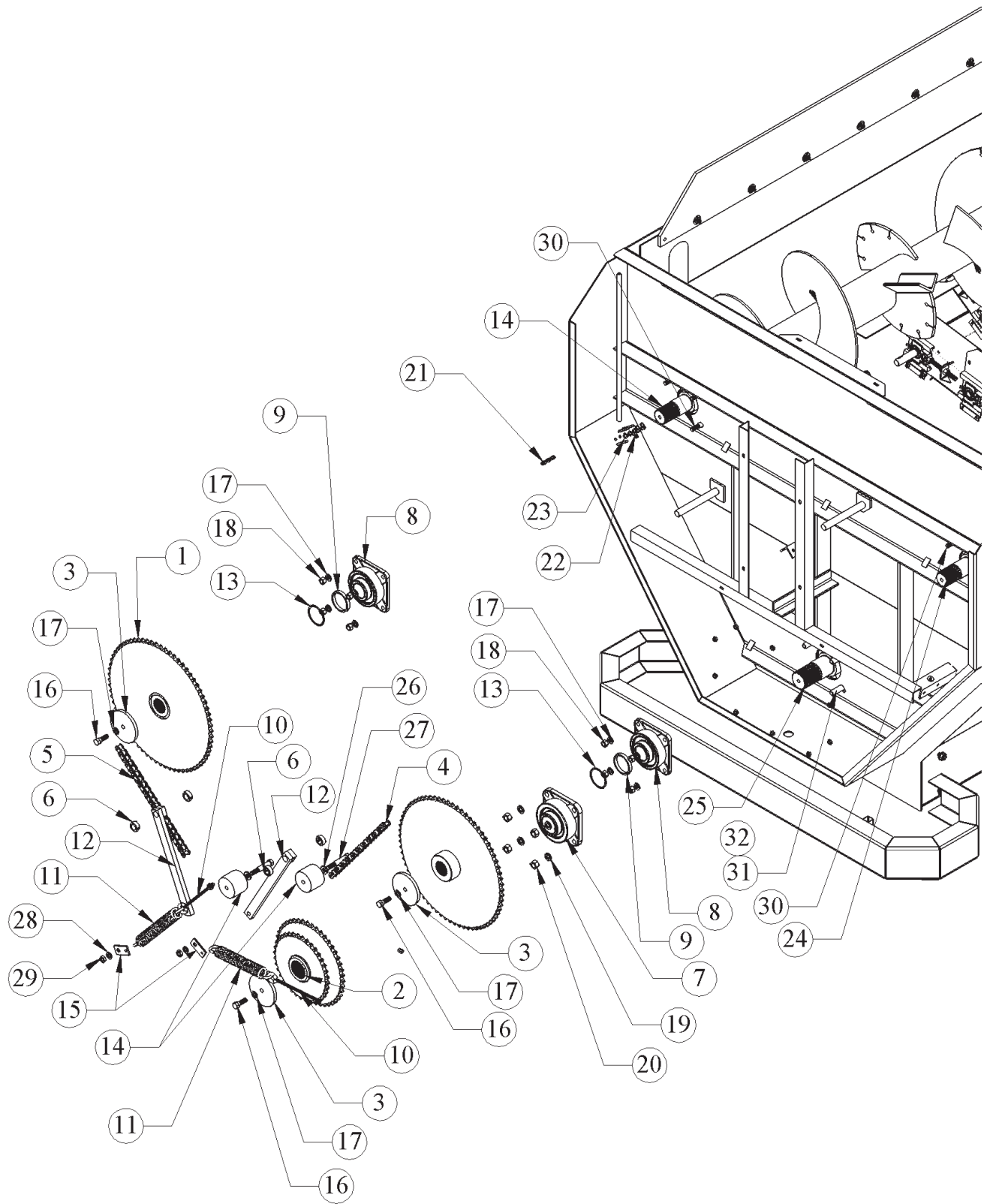

403-12 STANDARD DRIVE ASSEMBLY

NO.	PART NO.	DESCRIPTION	QTY.
1	850507	80B70 2.5"SPL B x 2.5"LTB WA	2
2	875441	Sprocket WA 80-36 x 80-45	1
3	185261	Washer, Shaft Spkt, 5 ½" O.D.	3
4	320852	Pitches #80 RC x 152	1
5	320847	Pitch Comp #80 RC x 148	1
6	412416	Set Collar 1" Pltd	4
7	340548	Bearing 3" 4-Blt Flange, Ball MSF-48	1
8	340540	Bearing 2.5" 4-Blt Flange, Ball MSF-40	2
9	185315	Shaft Sprocket Spacer 3" x ½"	2
10	410852	3/8" X 8" Eye Bolt	2
11	410012	Spring Pull 1 3/4" x 7 x .218	2
12	873054	Idler Arm WA 3/4 x 1 1/2 x 18	2
13	150598	Sprocket Spacer 3" x 1/16"	2
14	185582	Idler Block (#100)-2 7/8 x 5/8	2
15	187157	Pul Tab (5/8) 1/4 x 1 1/2 x 3	2
16	405754	HHCS #5 Pltd., 5/8"-11 x 2"	3
17	402010	Spring Lock Washer Med 5/8"	11
18	400210	Hex Nut #5 Pltd 5/8 / 11	8
19	402012	Lock Washer, Pltd. 3/4"	4
20	400212	3/4"-10 #5 Pltd Hex Nut	4
21	310750	Grease Zerk Pltd 1/8"	3
22	356001	90 DEG. 1/8" M NPFT x 3/16"	6
23	402506	3/8" Washer	3
24	875442	403 Auger Shaft Flange WA	2
25	875443	403 Rotor Rear Shaft WA	1
26	402510	SAE Flat Washer Pltd 5/8	2
27	405762	HHCS #5 Pltd 5/8-11 x 4	2
28	402110	External Star LW Pltd 5/8	2
29	400610	Hex Jam Nut #5 Pltd. 5/8-11	2
30	405756	HHCS #5 Pltd 5/8-11 x 2 ½	8
31	405783	HHCS #5 Pltd 5/8-11 x 3	4
32	171645	Bottom Bearing Hole Cover 8 x 8	1

403-12 HEAVY DRIVE ASSEMBLY (670130 HEAVY DRIVE KIT)

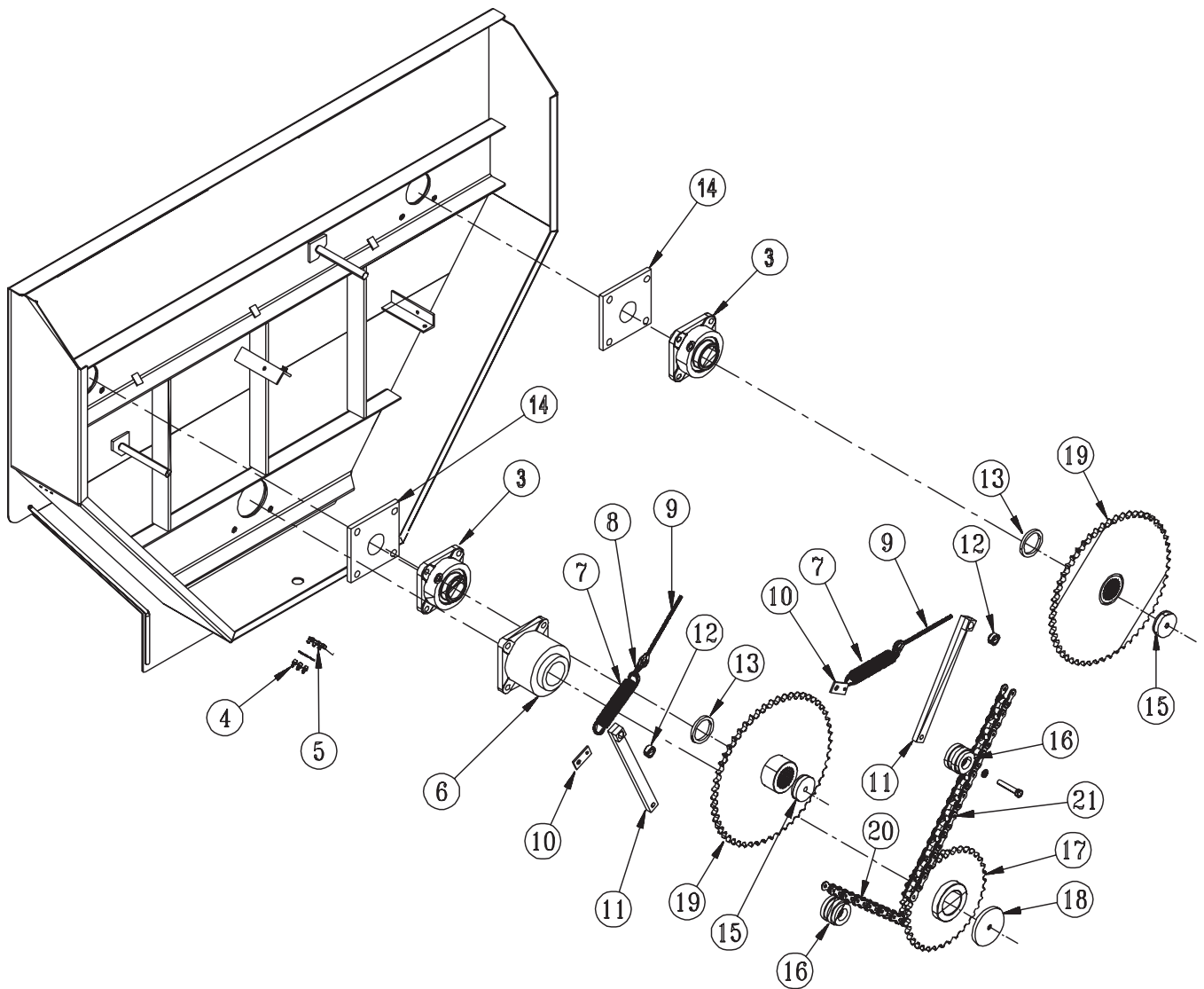

403-12 HEAVY DRIVE ASSEMBLY

KEY	PART NO.	DESCRIPTION	QTY.
3	340548	Brg 3-MSF 48-4 Blt Flange	2
4	310750	Fpt Grease Zerk Pltd 1/8	3
5	356001	Comp 90 Deg 1/8M NPFT X 3/16	3
6	342056	Brg Flg Roll Rex ZB2308-4	1
7	410012	Spring-Pull 1 3/4x7 x .218	2
9	410852	Eye Bolt 3/8 x 8 x 3/4 x 4	2
10	187157	Pull Tab (5/8) 1/4 x 1 1/2 x 3	1
11	873054	Idler Arm WA-3/4X1 1/2X18	1
12	412416	Set Collar Pltd 1"	4
13	171337	Shaft Spacer - 3" x 3/8"	2
14	171338	3" Bearing Spacer	2
15	850129	End Cap WA-3 1/2	2
16	185582	Idler Block, 2 7/8 x 5/8	1
17	875370	100-28 x 100-36 Sprkt WA	1
19	850521	100B54 3" SPL Bore x 3" LTB WA	2
20	321116	Pitch Comp #100 x 116	1
21	321120	Pitch Comp #100RC x 120	1

OIL BATH DOOR GROUP

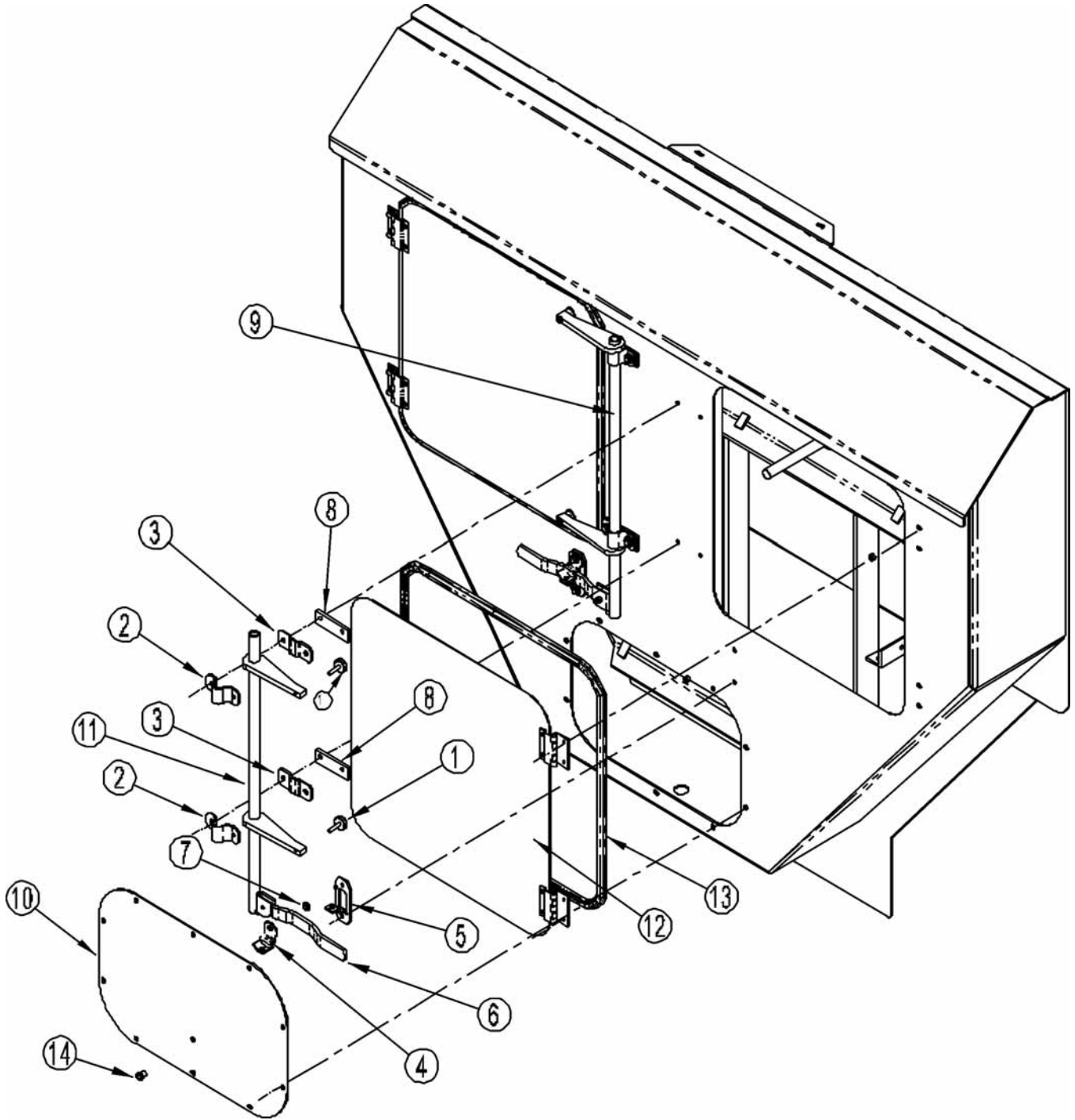

OIL BATH DOOR GROUP

KEY	PART NO.	DESCRIPTION	QTY.
1	370323	Leveling Pad	4
2	370316	Cam Lock Top Plate (3/4 Pipe)	4
3	370317	Cam Lock Bottom Plate	4
4	370320	Handle Cam Lock	2
5	370322	Handle Stop	2
6	370319	Cam Lock Handles	2
7	370321	Cam Lock Bushing	2
8	189503	Cam Rod Spacer 4-1/2"	4
9	875363	L.H. Cam Lock WA	1
10	171307	Lower O.B. Door 17-1/2 x 26-1/2	1
11	875364	R.H. Cam Lock WA	1
12	875366	O.B. Door WA	2
13	351056	5/32, Rubber Bulb Seal	18
14	310720	Plug, Pipe Sight, Pltd 3/8	1

DISCHARGE DOOR & EXTENSION

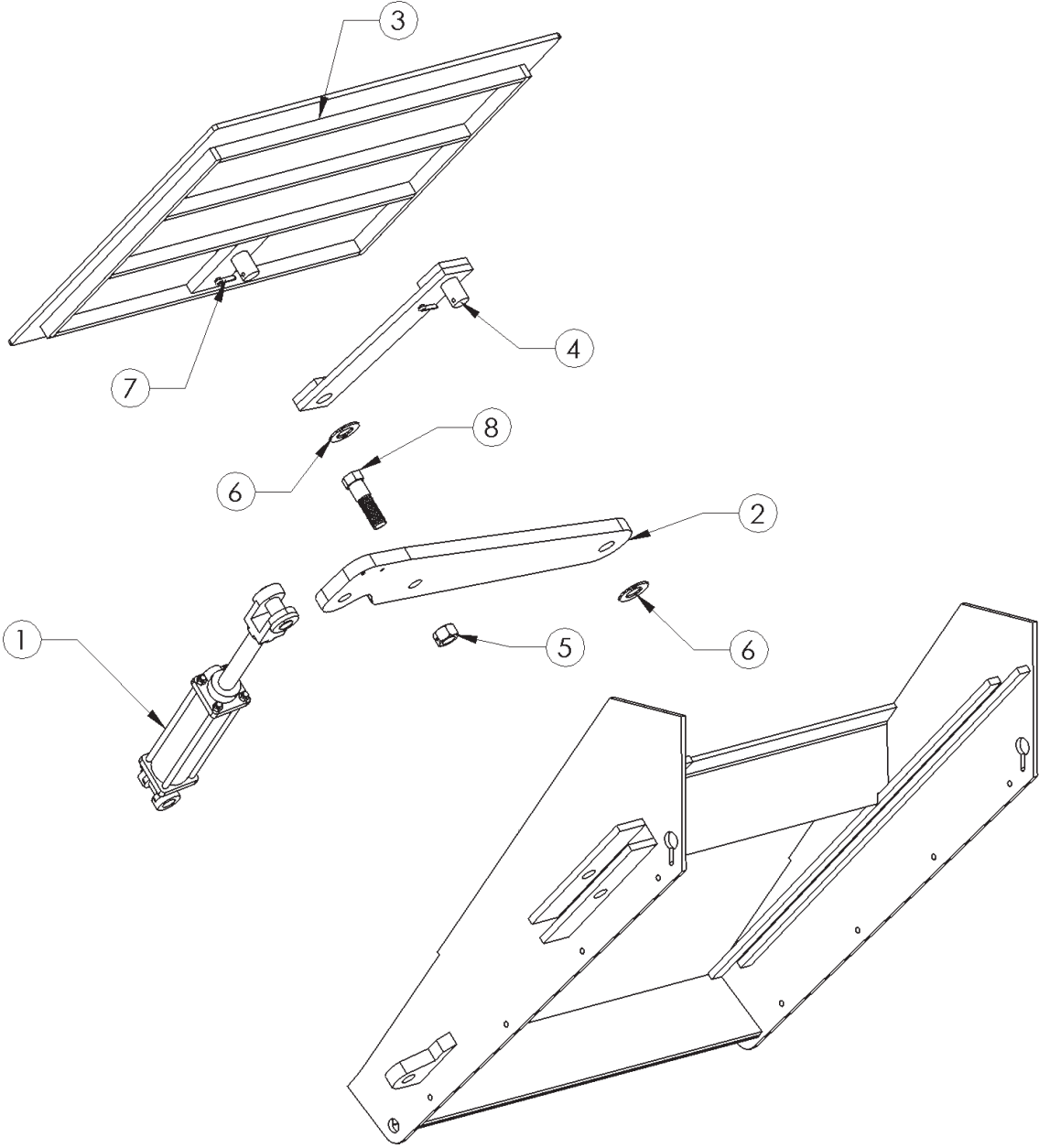

DISCHARGE DOOR AND EXTENSION

KEY	PART NO.	DESCRIPTION	QTY.
1	364057	Hyd. Cyl. 20-1/4 CC 2-1/2" x 8"	1
2	171574	Door Pivot Bar - 31 13/16"	1
3	875440	403 Discharge Door W.A.	1
4	872248	Straight Door Arm W.A.	1
5	400916	1"-8 #5 Pltd Two-Way Hex Locknut	1
6	402518	1-1/8" SAE Flat Washer Pltd	2
7	404000	5/32" Cotter Pin x 1 1/4"	2
8	405832	HHCS. #5 Pltd 1- 8 x 3 1/2"	1

DISCHARGE CONVEYOR

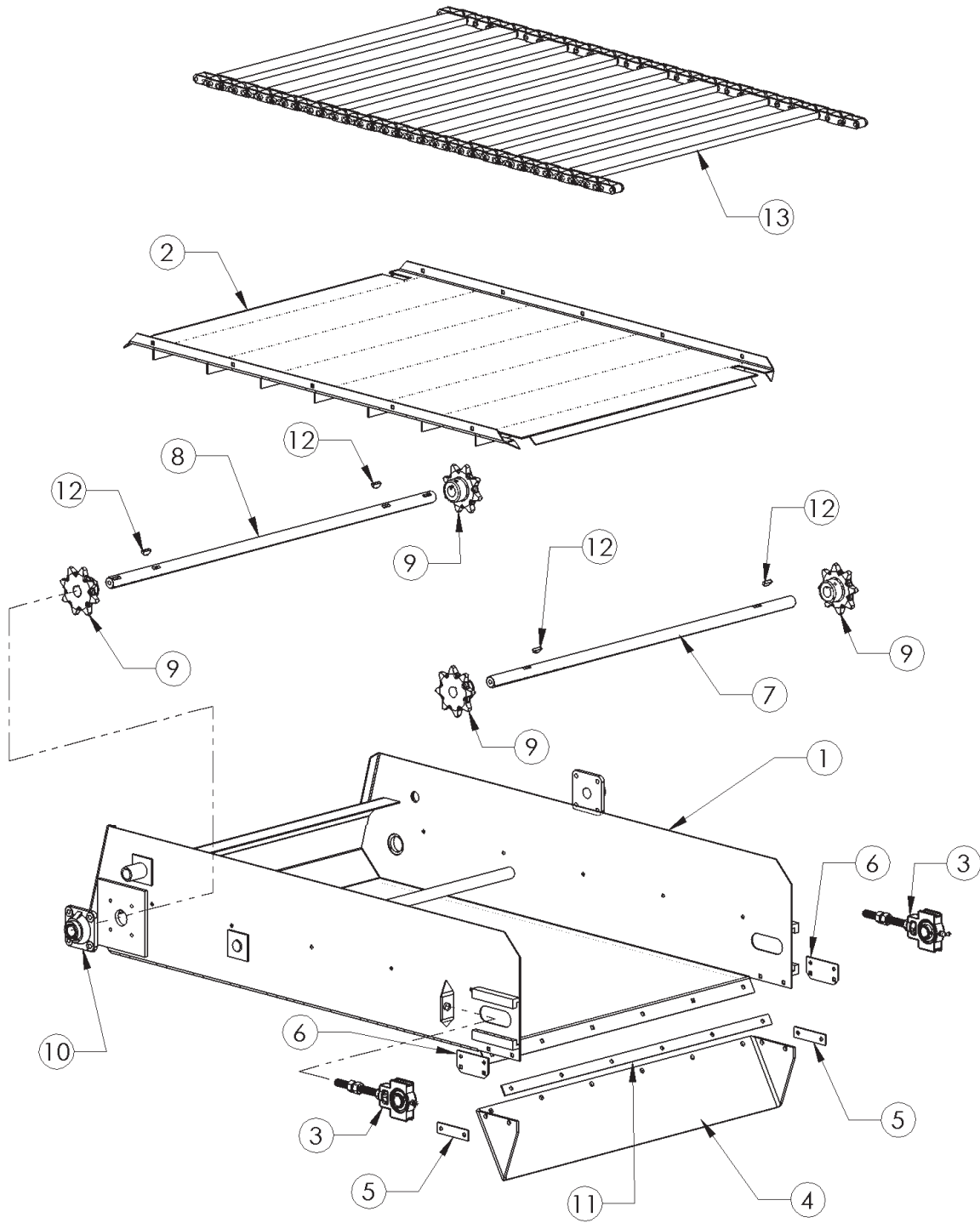

DISCHARGE CONVEYOR

KEY	PART NO.	DESCRIPTION	QTY.
1	874120	36" W x 48" L Conveyor WA	1
	874112	36" W/L Conveyor WA	
2	874118	36" W x 48" L Convy Pan WA	1
	874110	36" W/L Convy Pan WA	
3	760000	1" Conv Take Up Bearing	2
4	188417	36" Convy Spout Rubber - 44 3/4"	1
5	188304	Conveyor Spout Rubber Bar - 4"	2
6	188418	Spout Rubber Side Bar - 4"	2
7	188413	36" Convy. Idler Shaft - 39"	1
8	188412	36" Convy. Drive Shaft - 40"	1
9	160025	Sprocket, Conveyor-C55 8T 1"ID	4
10	340316	Brg. 1" 4-Bolt Flg UCF 205-16	2
11	188302	Conveyor Spout Rubber Bar 34-1/2"	1
12	409916	Key 1/4 x 1" Woodruff	4
13	874119	C55x67 Convy Chain WA (36" W x 48" L Conveyor)	1
	874111	C55x52 Convy Chain WA (36" W/L Conveyor)	1

403 CONVEYOR MOUNT KIT - FIXED

KEY	PART NO.	DESCRIPTION	QTY.
1	332654	Coupling 1"ID x 2" OD x 3"LTB w/ 1/4	1
6	409916	Key, 1/4 x 1" Woodruff	1
7	874071	Conveyor Motor Plate	1
9	181529	Shaft, Door Hinge, 45 1/2	1
12	875388	Conveyor Lift Plate WA	2
14	412004	Log Chain - Pltd 1/4"	4
19	171419	Lift Plate 3 x 4 3/4	2
20	360009*	Hyd. Motor 101-1012 9.7 cu in	1

TRAILER HYDRAULIC KIT - FIXED CONVEYOR

KEY	PART NO.	DESCRIPTION	QTY.
1	781300	Hose, Hyd, ½ x 174	2
2	781319	Hose, Hyd, 3/8 x 174	1
3	781320	Hose, Hyd, 3/8 x 184	1
4	368118	Swivel, Str Adp 7/8MOR x 1/2FP	1
5	362240	Check Valve 1/2FP x 1/2FP	1
6	368031	Swivel 90° 1/2MP x 1/2FP	1
7	368007	90° 3/8MP x 3/8FPS w/ .109	2
8	368047	Swivel 90° 7/8MOR x 1/2FP	1
9	368642	Hex Nipple 1/2MP x 1/2MP	1
10	310828	V83073 Pipe Cap ½ NPT Blk	4

403 CONVEYOR MOUNT KIT - HYD. LIFT

KEY	PART NO.	DESCRIPTION	QTY.
1	332654	Coupling 1"ID x 2" OD x 3"LTB w/ 1/4	1
6	409916	Key, 1/4 x 1" Woodruff	1
7	874071	Conveyor Motor Plate	1
9	181529	Shaft, Door Hinge, 45 1/2	1
12	875388	Conveyor Lift Plate WA	2
16	875385	533 Cable Pulley WA	2
17	875386	Door Cylinder Bracket	1
20	171400	Bushing 1 1/2"OD x 1 1/64" ID	1
26	171422	Eye Bolt Pin 2 7/8	1
27	171423	Eye Bolt Sleeve 1	2
28	412206	Cable Clamp Pltd 5/16	8
29	171425	Cable 5/16 x 102"	1
30	171424	Cable 5/16 x 152	1
32	410861	Eye Bolt 1/2-13 x 6 x 1 x 8 x 4	2
34	171287	Door Cyl Pivot Arm 6	1
35	360009	Hyd Motor 101-1012 9.7 cu in	1

TRAILER HYDRAULIC KIT - HYD CONVEYOR

KEY	PART NO.	DESCRIPTION	QTY.
1	780109	Strt Door Cylinder 2 x 8	1
2	781369	Hose Assy, ½ x 148, 1/2MP	2
3	368118	Swivel, Str Adp 7/8MOR x 1/2FP	1
4	368608	Serv Tee 1/2MP x Two 1/2FP	2
5	368111	Str Adp 1/2MP x 12FP Swivel	1
6	368025	Swivel 45° L 3/8MP x 3/8FP	2
7	362240	Check Valve 1/2FP x 1/2FP	1
8	368317	Str Adp 7/8MOR x 1/2MP	1
9	368610	Bushing, 1/2MP x 3/8FP Pipe	2
10	781334	Hose, Hyd, 3/8" x 134"	1
11	781370	Hose, Hyd, 3/8" x 120"	1
12	368007	90° 3/8MP x 3/8FPS w/.109	2
13	781377	Hose, Hyd, 3/8" x 168"	1
14	781378	Hose, Hyd, 3/8" x 180"	1
15	310828	V83073 Pipe Cap 1/2PT Blk	4
16	368029	Swivel 45° L 1/2MP x 1/2FP	1

TRAILER, BATTERY BOX & WEIGH BARS

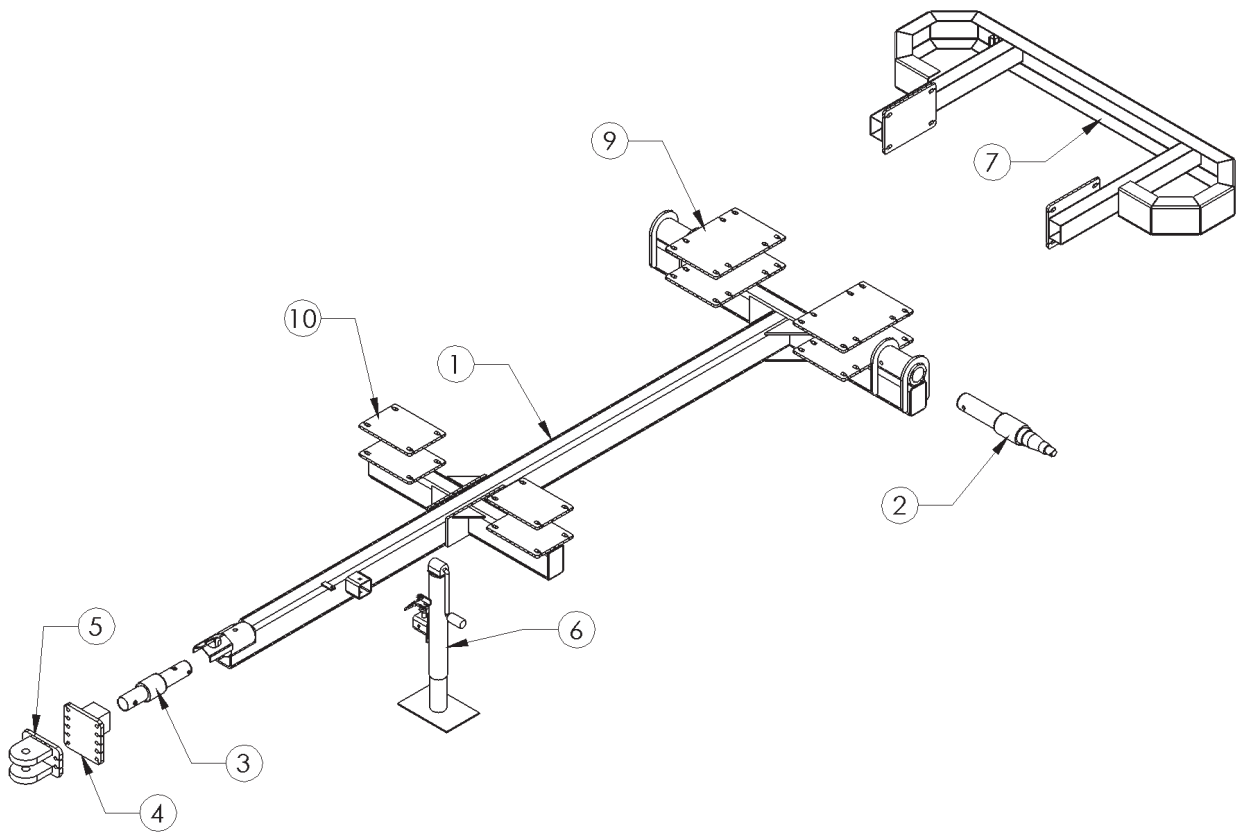

TRAILER, BATTERY BOX & WEIGH BARS

KEY	PART NO.	DESCRIPTION	QTY.
1	875433	403 Trailer W.A.	1
2	450711	Axle Bar, 2 7/8 12K Hub	2
3	450756	Weigh Bar, 2 1/2" Hitch	1
4	860354	Hitch Plate Tube WA	1
5	860370	VXT Clevis Hitch WA	1
6	875384	533 Mixer Jack WA	2
7	875380	533 Trailer Bumper WA	1
9	875397	Rear 4" Riser WA (Optional)	2
10	875396	Front 4" Riser WA (Optional)	2
NS	357400	Battery Box w/Strap 7.5 x 11	1

HUB ASSEMBLY & WHEEL ASSEMBLY

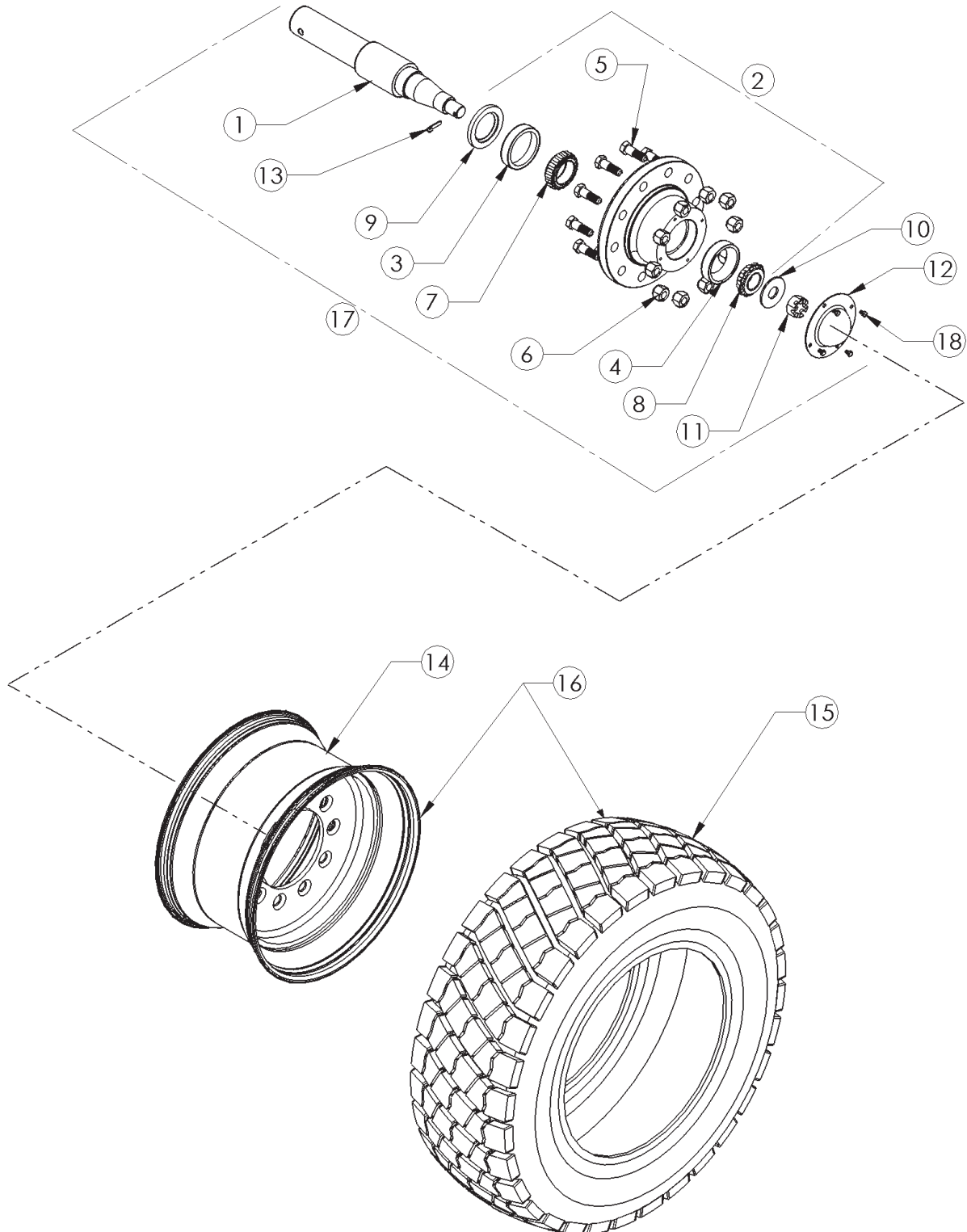

HUB ASSEMBLY & WHEEL ASSEMBLY

KEY	PART NO.	DESCRIPTION	QTY.
1	450711	Axle Bar Cell, 2 7/8" 12K Hub	2
2	372209A	10 Bolt Hub 12000LB (Inc. Items 3,4,5 & 6)	2
3	342211	Inner Race,	1
4	342212	Outer Race,	1
5	407724	Stud Bolt	10
6	400102	Hex Flanged Nut,	10
7	342209	Bearing, 2.5 Bore Tim #39585	1
8	342210	Bearing, 1.75 Bore Tim #460	1
9	372321	Seal, 2 7/8" Bore x 4 1/2"OD	1
10	402911	Washer 3.25" OD x 1.22" ID x .19 Thk	1
11	401820	1 1/4-12 Hex Cstl Nut SAE Plt	1
13	404003	5/32" Cotter Pin x 1 1/4"	1
12	372308	Dust Cap, 12000 LB AXLE	1
14	372422	Wheel, 13" x 22.5" 10 Bolt Bud	1
15	372614	Tire, Lug Tread Only 15 x 22.5	1
16	781209	15 x 22.5 Tire & 10 Wheel	1
17	760130	Trl 10 Bolt Hub & WB Assy	2
18	405625	HHCS #5 Pltd 5/16 x 1/2	4

TRUCK FENDERS

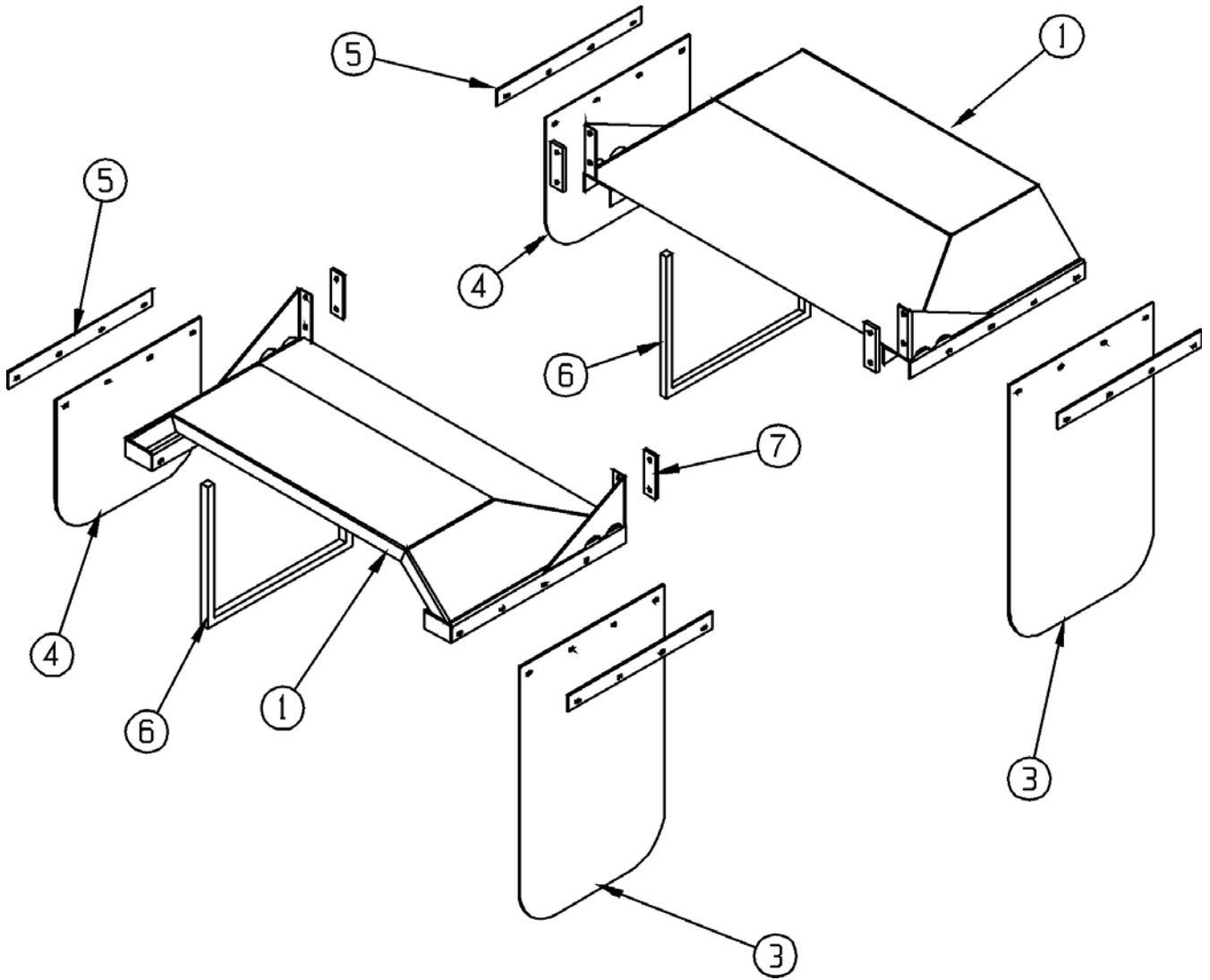

TRUCK FENDERS

KEY	PART NO.	DESCRIPTION	QTY.
1	875394	Single Axle Fender Weldment	2
3	370200	Rear Mud Flap	2
4	370202	Front Mud Flap	2
5	183087	Mud Flap Strap	4
6	872120	Mud Flap Bracket Weldment	2
7	171430	Bracket	4

LADDER, RAILS, & PLATFORM - TRUCK

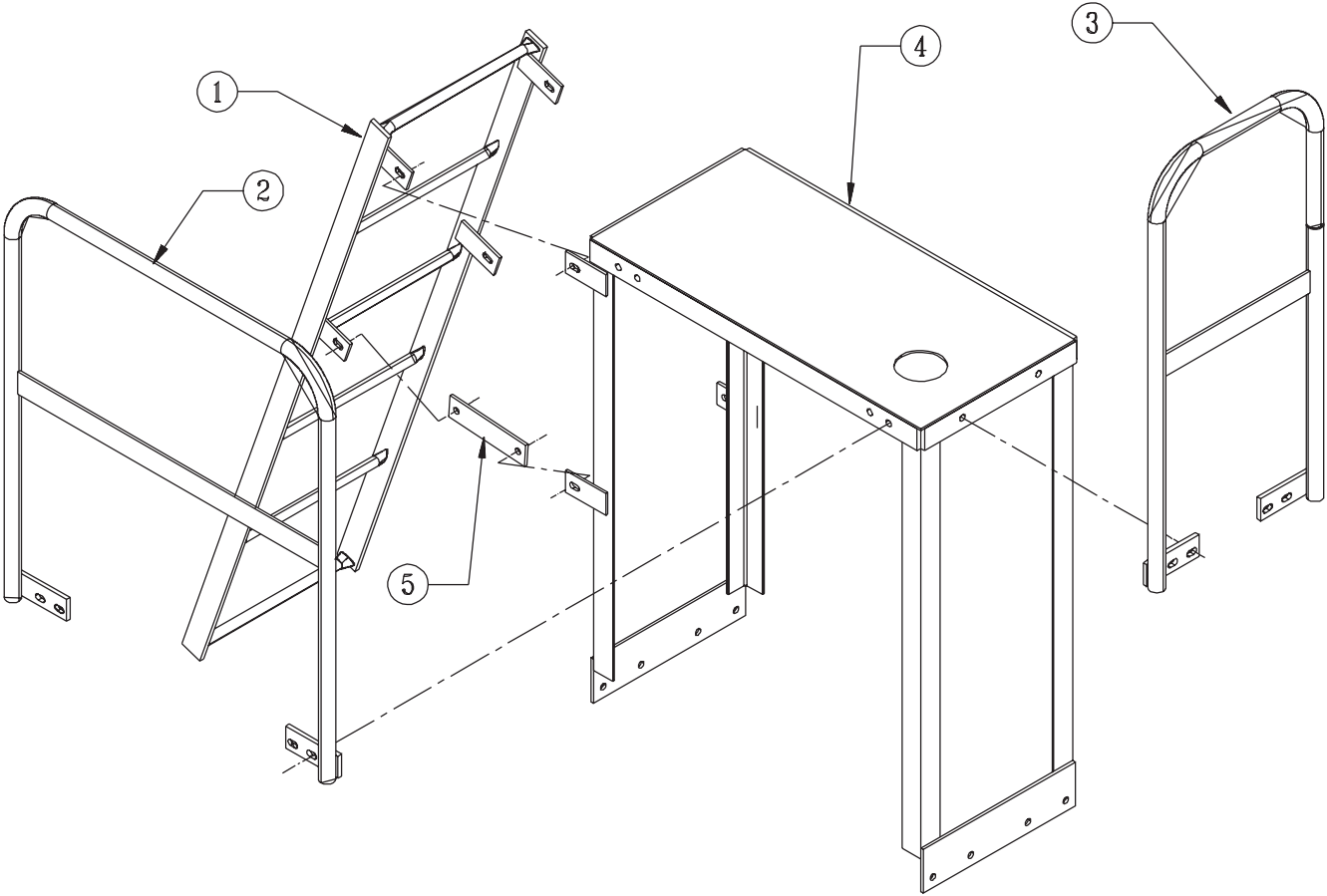

LADDER, RAILS, & PLATFORM - TRUCK

KEY	PART NO.	DESCRIPTION	QTY.
1	872273	Trailer Ladder WA	1
2	872608	Handrail WA	1
3	872745	End Handrail WA	1
4	872607	920 Platform WA	1
5	171452	Ladder Bar-8"	2

SCALE INDICATOR ARM ASSEMBLY

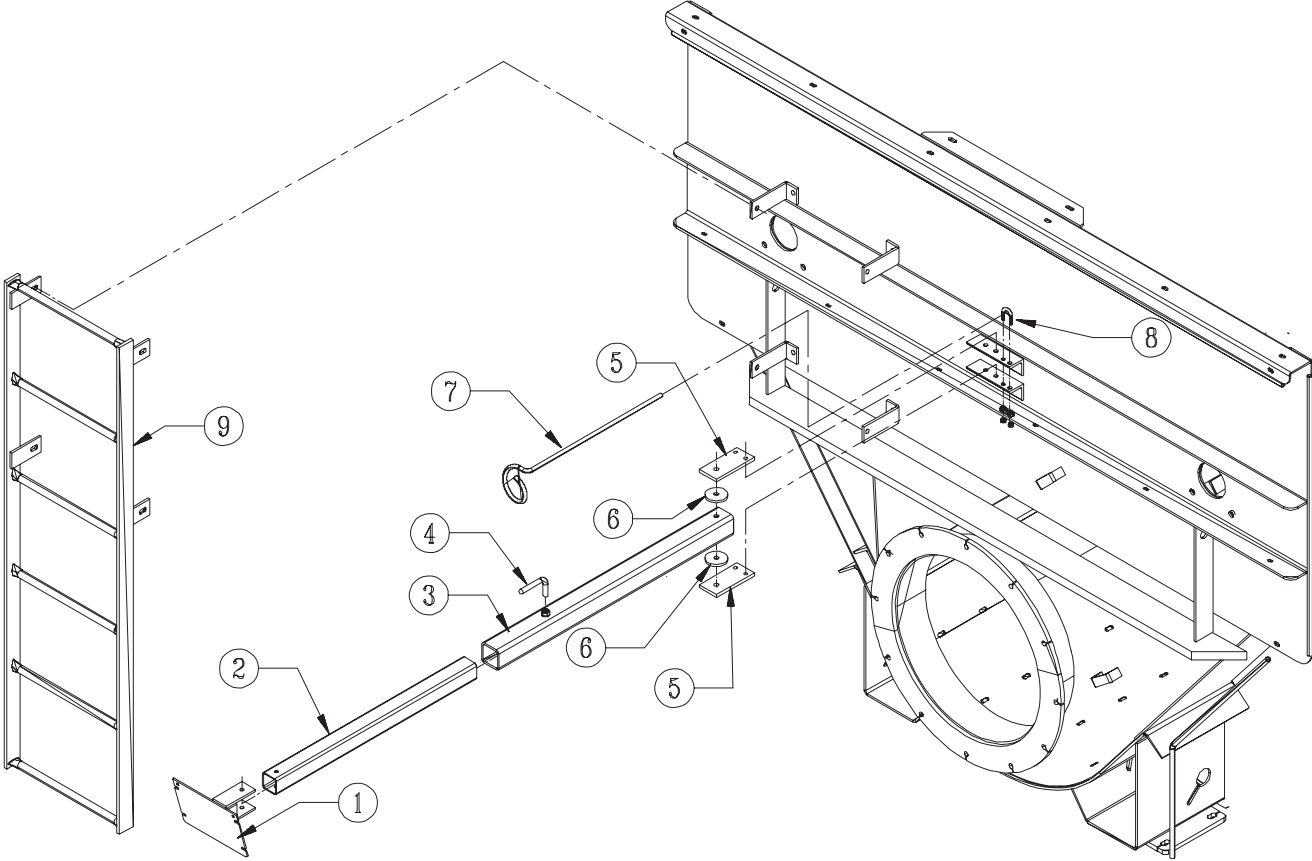

SCALE INDICATOR ARM ASSEMBLY

KEY	PART NO.	DESCRIPTION	QTY.
1	872126	Trl Scale Ind Arm WA-2sq X 3	1
2	185490	Tube, Trl Scale Indicator, 29	1
3	872125	Trl Scale Arm WA-2 1/2sq X 34	1
4	185492	Handle, 1/2" Locking, 6	1
5	185491	Plate, Trl Scale Hinge, 5 1/2	2
6	185493	Washer, Scale Hinge, 2 1/2 OD	2
7	184283	Trailer, Hose Carrier, 36	1
8	412205	Cable Clamp Pltd 3/8"	1
9	780288	Trailer Ladder	1

**403-12 TRAILER
PTO SHAFT - 540 RPM
P/N 338035**

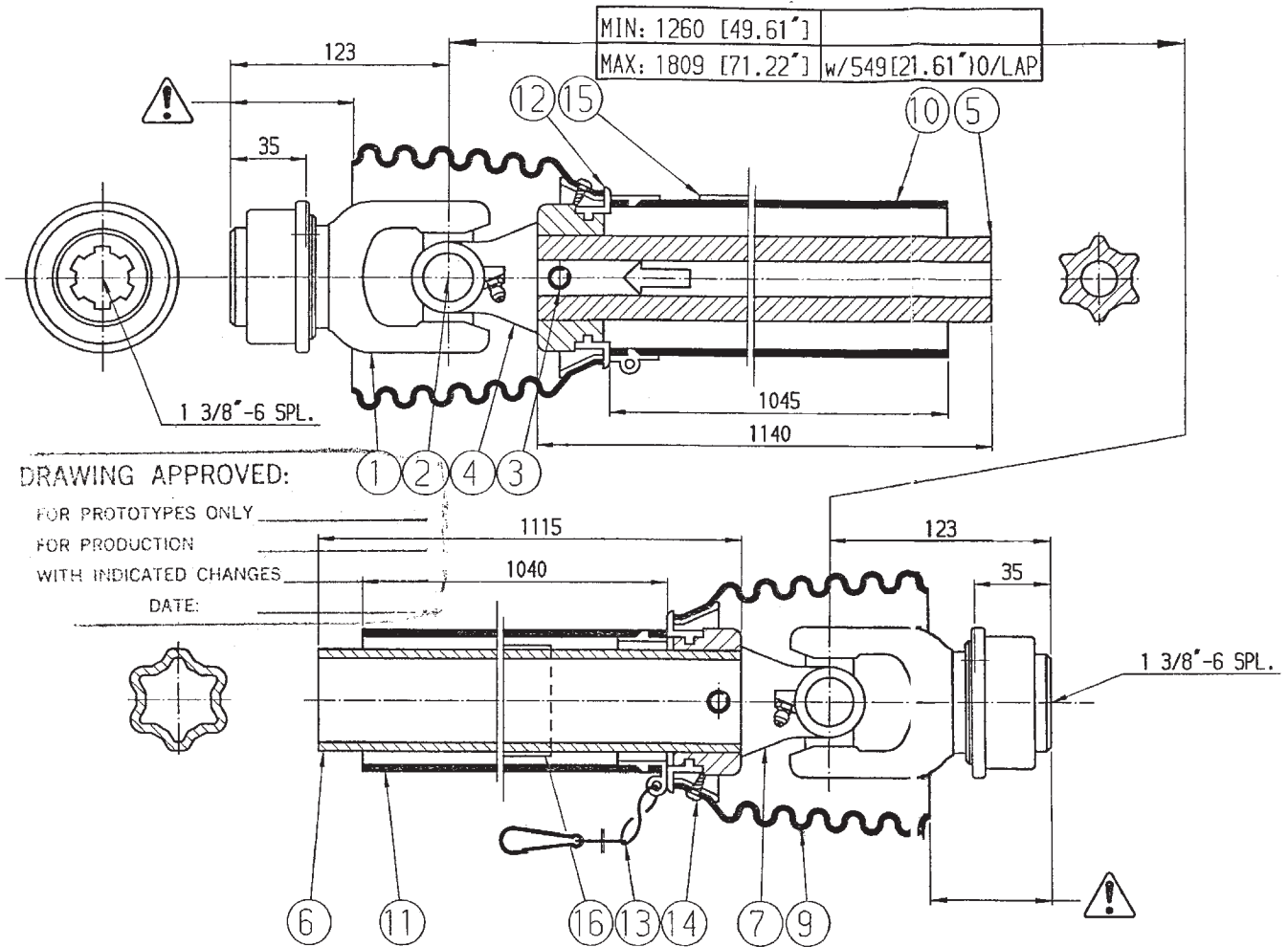

**403-12 TRAILER
PTO SHAFT - 540 RPM**

KEY	PART NO.	DESCRIPTION	QTY.
1	338507	Yoke 1 3/8"-6 Spl. ASG	2
2	338443	Cross Kit W2400-312410	2
3	338473	Spring Pin 10 x 80	2
4	338564	Inboard Yoke S4	1
5	338568	Inner Profile S4	1
6	338569	Outer Profile S5	1
7	338562	Inboard Yoke S5	1
9	338486	Shield Cone 6 Rib	2
10	338487	Outer Shield Tube Oval	1
11	338488	Inner Shield Tube Round	1
12	338489	Bearing Ring SC25	2
13		Safety Chain (044321)	1
14		Screw-In Item 9 (365305)	2
15		Decal Outer - In Item 10 (383333)	1
16		Decal Inner - In Item 6 (383334)	2
17		ADMA Safety Manual (391606)	1
NS		ASG Col. Kit - In Item 1 (381908)	2